

AUTOMATIC TECHNOLOGY AUSTRALIA PTY LTD

GDO-4 V4 EasyRoller[®]

ROLL UP GARAGE DOOR OPENER



OWNERS COPY

Installation Instructions





















Warning: It is vital for the safety of persons to follow all instructions. Failure to comply with the installation instructions and the safety warnings may result in serious personal injury and/or property and remote control opener damage. Please save these instructions for future reference.

TABLE OF CONTENTS

Safety Warnings.....	4
Product Features.....	5
Operating Controls.....	6
Package Contents.....	8
Side Room Requirements.....	9
Fixing Weight Bars.....	9
Left/Right Hand Installation.....	9
Easy Access Transmitter.....	10
Mounting The Opener.....	11
Fixing Curtain To Drum.....	12
Setting Limits Via Control Panel.....	12
Setting Limits Via Transmitter.....	13
Setting Obstruction Force Margin (ISS).....	14
Coding Transmitters	15
Fitting Locking Bar Covers	16
Connecting Photo Electric Beam.....	17
Setting Auto-Close Time.....	17
Using Manual Release.....	17
Setting Courtesy Light Time.....	18
Setting Pet Mode Door Opening Position.....	18
Re-Initialising Door Opener.....	18
Door Status Indicators.....	19
Buttons and Functions.....	19
Factory Default Settings.....	20
Technical Specifications.....	20
Trouble Shooting Guide.....	21
Parts List.....	22
Warranty.....	23

IMPORTANT SAFETY INSTRUCTIONS

Warning - It is vital for the safety of persons to follow all instructions. Failure to comply with the following Safety Rules may result in serious personal injury and/or property damage.

-  For **ADDITIONAL SAFETY** protection we **STRONGLY** recommend the fitting of a Photo Electric Beam. In most countries Photo Electric Beams are mandatory on all garage doors fitted with automatic openers. For a small additional outlay ATA recommends that Photo Electric Beams be installed with the automatic opener ensuring additional safety and peace of mind.
-  **DO NOT** operate the garage door opener unless the garage door is in full view and free from objects such as cars and children/people. Make sure that the door finished moving before entering or leaving the garage.
-  **DO NOT** operate the garage door opener when children/persons are near the door. Children must be supervised near the garage door at all times when the door opener is in use. **SERIOUS PERSONAL INJURY** and/or property damage can result from failure to follow this warning.
-  **DO NOT** allow children to operate the garage door opener. **SERIOUS PERSONAL INJURY** and/or property damage can result from failure to follow this warning.
-  Regularly check to make sure that the **SAFETY OBSTRUCTION FORCE** is working correctly, and is **TESTED** (by placing a 50mm high object on the floor) and set as per the Installation Instructions Manual. Failure to follow the manual could result in **SERIOUS PERSONAL INJURY** and/or property damage. This test must be repeated at regular intervals and the necessary adjustments made as required.
-  **DO NOT** disengage the door opener to manual operation with children/persons or any other objects including motor vehicle within the doorway.
-  Install the wall switch or wall mounted transmitter in a **LOCATION/POSITION** where it is out of reach of children and the garage door is visible.
-  The door opener is not intended for use by young children or infirm persons without adequate supervision. Children should be supervised to ensure that they do not play with the remote transmitters or the opener.
-  Keep hands and loose clothing **CLEAR** of the door and door opener at all times.
-  The unit should be installed so that it is protected from the elements. It should not be exposed to water or rain. It is not to be immersed in water or sprayed directly by a hose or other water carrying device.
-  The garage door must be **WELL BALANCED**. Sticking or binding doors must be repaired by a qualified garage door installer prior to installation of the opener.
-  Frequently examine the installation, in particular cables, springs and mountings for signs of wear, damage or imbalance. **DO NOT** use if repair or adjustment is needed since a fault in the installation or an incorrectly balanced door may cause injury. **DO NOT** attempt to repair the door yourself as hardware is under extreme tension.
-  **REMOVE OR DISENGAGE** all garage doors locks and mechanisms prior to installation of the opener.
-  Connect the garage door opener to a properly **EARTHED** general purpose 240V mains power outlet installed by a qualified electrical contractor.
-  **DISCONNECT THE POWER CORD** from mains power before making any repairs or removing covers. Only **EXPERIENCED** service personnel should remove covers from the garage door opener.
-  When using auto close mode, a **PHOTO ELECTRIC BEAM** must be fitted correctly and tested for operation at regular intervals. **EXTREME CAUTION** is recommended when using auto close mode. **ALL SAFETY RULES** must be followed.
-  In order for the garage door opener to **SENSE** an object obstructing the door way, some **FORCE** must be exerted on the object. As a result the object, door and/or person may suffer **DAMAGE or INJURY**.
-  If the power supply cord is damaged, it **MUST** be replaced by an ATA service agent or suitably qualified person.
-  Make sure that the door is fully open before driving in or out of the garage and fully closed before leaving the driveway.
-  Make sure that remote controls are kept out of reach of children.

Automatic Technology Australia Pty Ltd to the extent that such may be lawfully excluded hereby expressly disclaims all conditions or warranties, statutory or otherwise which may be implied by laws as conditions or warranties of purchase of an Automatic Technology Australia Pty Ltd Roll Up Garage Door Opener. Automatic Technology Australia Pty Ltd hereby further expressly excludes all or any liability for any injury, damage, cost, expense or claim whatsoever suffered by any person as a result whether directly or indirectly from failure to install the Automatic Technology Australia Roll Up Garage Door Opener in accordance with these installation instructions.

FEATURES

Thank you for purchasing the ATA EasyRoller Automatic Garage Door Opener. This opener is designed to suit vertical operating continuous curtain roll up doors. The components and materials used in this opener are of the latest technology and highest quality. Listed below are some of the many features.

OPERATION

To open or close the door simply press the hand held transmitter, the wall mounted transmitter, or optional wall switch for two seconds. During an open cycle the door can be stopped by pressing the button while the door is in motion. If it is interrupted during a close cycle the door will pause briefly then return to the fully open position. The next actuation will move the door in the opposite direction.

HOPPING CODE

Every time a transmission is made from the *remote* transmitter a new security code is generated. The number of possible code combinations is over 4.29 billion. This greatly enhances the security of the system. Code "grabbing" is made a thing of the past.

ALPS (AUTOMATIC LIMITS POSITIONING SYSTEM)

A revolutionary door travel limits positioning system., the new ALPS technology does away with manual adjustment of the doors' limits position using mechanical parts, for example micro switches and cams.

The ALPS technology automatically calculates the doors' travel limits and stores it in memory. If the door is moved manually within the travel limits during a power failure, the ALPS will recognise this once the power is restored and stop at the correct limit position if the door is activated.

During installation the hand held transmitter can be programmed to set the door limits positions.

ISS (INTELLIGENT SAFETY OBSTRUCTION SYSTEM)

While the door is performing a close cycle, should it hit an obstacle or be restricted in some manner, it will automatically reverse. The amount of force the door should encounter before reversing is automatically adjusted by the doors control system during the initial installation of the automatic door opener. The door will also stop if restricted whilst opening. The Safety Obstruction Force should be checked at least once a month. See installation manual for instructions.

SECURITY CODE STORE

The EasyRoller Garage Door Opener uses state of the art technology in storing your selected transmitter security code. Up to 23 different transmitters can be stored in the openers memory.

OVER LOAD INDICATOR

When the maximum opening and closing capacity of the opener is exceeded an audible beeper will sound to indicate that an overload has occurred.

AUTO COURTESY LIGHT

The courtesy light on the opener comes on automatically whenever the door is activated. The light can also be switched on and off without operating the door. This is done by pressing the button on any hand held or wall mounted transmitter which has been stored with the light code. The light will stay on for approximately three minutes then switch off. This time is also adjustable.

VACATION MODE

A hand held transmitter can be programmed to lock and unlock all other transmitters that have being programmed into the openers' memory. The vacation mode can be used when the door is left idle for long periods of time.

PET (PEDESTRIAN) MODE

The hand held transmitter can be programmed to open the door partially so that the family pet can enter and exit the garage at any time. You may also wish to open the door to a height suitable only for pedestrian access. The door opening position is also programmable.

AUTO CLOSE MODE

The opener can be programmed to automatically close after an open cycle. The auto close time is adjustable. It is compulsory to install a Photo Electric Beam if this mode is selected, otherwise the door may cause personal injury or damage to property.

PHOTO ELECTRIC BEAM (OPTIONAL)

The opener has an input for a photo electric beam to be connected for extra safety protection and use of the auto close mode.

MANUAL OPERATION

The opener is equipped with a unique patented manual disengaging device. If the power to the opener is disrupted for any reason the door can be put into manual mode by pulling down on the string handle, then releasing. This will allow you to manually open or close the door. When power is restored, by pulling down on the string handle and releasing, the opener is put back into automatic mode.

OPERATING CONTROLS

- 1. LIGHT CODE button** (white) is used for storing or erasing the transmitter button (code) you wish to use to switch the opener's courtesy light on and off.
- 2. CODING LED** (red) light flashes when a code is being stored or when a transmitter button is pressed.
- 3. DOOR CODE button** (blue) is used for storing or erasing the transmitter button you wish to use to command the door to open, stop or close.
- 4. P. E. SHUNT.** The shunt has to be removed when connecting a Photo Electric Beam.
NOTE: P.E. SHUNT must not be removed otherwise the opener will not function correctly. Remove only when a P.E beam is to be connected.
- 6. RX INPUT** is used for the connection of an external receiver. The receiver input can supply 30mA at 24 volts DC maximum to power an external receiver.
- 7. PROG INPUT** is used for the connection of the ATA Universal Programmer for the purpose of editing control and receiver functions.
- 8. CLOSE drive button** (red) is used during installation to help set the close limit position. Pressing and holding this button will move the door in the close direction. Movement stops when the button is released.

NOTE: The close safety obstruction detection is inoperable whenever the Close Drive button is used to move door.
- 9. CLOSE LIMIT LED** (red) the led is very helpful during installation. It illuminates and flashes when the door is closing and remains steady on when the close limit position has been reached.
- 10. O/S/C INPUT** is used for the connection of a wired switch (momentary contact). This switch can then be used to open, stop or close the door. Install the wall switch in a location where the switch is out of reach of children and the garage door is visible.
- 11. AUTO CLOSE TIME button** (White) is used to adjust the auto close time. While holding in the auto close button and then pressing the open button the time is increased. Each press will increase the time by 5 seconds. Pressing the close button will decrease the time.
- 12. MOTOR CONNECTOR** is used to select the direction of rotation of the Motor. The connector has to be moved left or right depending on which side of the Roll Up Door the Opener is to be installed.
- 13. BATTERY CHARGER INPUT** is used for the connection of a battery charger.
- 14. FORCE MARGIN SET** The obstruction force pressure is set automatically by the opener during installation. The pressure can be adjusted manually using the Force Margin Set button (White). Pressing the force margin set button and open or close button will increase or decrease the amount of force. The Force Margin Set is only ever used if other environmental factors (wind, etc.) effect the operations of the door/opener.
- 15. OPEN LIMIT LED** (green) the led is very helpful during installation. It illuminates and flashes when the door is opening and remains steady on when the open limit position has been reached.
- 16. OPEN DRIVE button** (green) is used during installation to help set the open limit position. Pressing and holding this button will move the door in the open direction. Movement stops when the button is released.
NOTE: The open safety obstruction detection is inoperable whenever the Close Drive button is used to move door.
- 17. O/S/C button** (Yellow) is used during installation to test the open, stop and close cycles for the opener. The opener has to be initialised by the Reset button before the O/S/C button becomes operable.
- 18. SET button** (yellow) is used during the installation phase together with the Open and Close buttons to set the door limit positions. The Set button is also used to re-initialise the Opener.
- 19. ENGAGE/DISENGAGEMENT CORD** when pulled down and released this will select manual mode on the opener, particularly when there is a power failure. Pulling down and again releasing will select automatic mode on the opener. The length of the string is adjustable.
- 20. EASY ACCESS TRANSMITTER** The "manual release" engage/disengagement handle has within its housing a wireless transmitter. If the button is pressed it will open, stop or close the garage door.

OPERATING CONTROLS

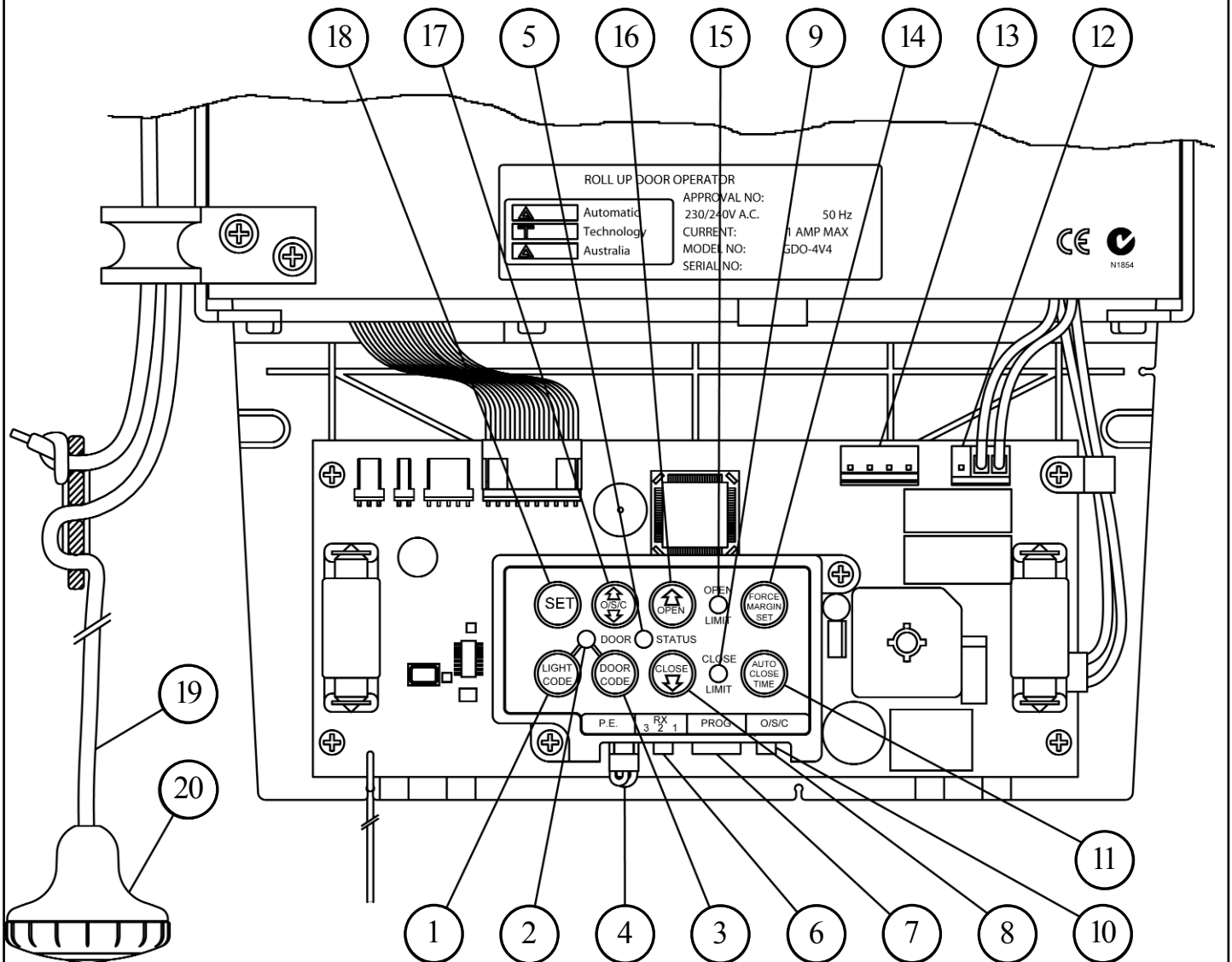

- | | |
|--|---|
| <p>1) LIGHT CODE BUTTON (WHITE)</p> <p>2) CODING LED (RED)</p> <p>3) DOOR CODE BUTTON (BLUE)</p> <p>4) P.E. SHUNT</p> <p>5) DOOR STATUS LED (YELLOW)</p> <p>6) RX INPUT</p> <p>7) PROG INPUT</p> <p>8) CLOSE DRIVE BUTTON (RED)</p> <p>9) CLOSE LIMIT LED (RED)</p> <p>10) O/S/C INPUT</p> | <p>11) AUTO CLOSE BUTTON (WHITE)</p> <p>12) MOTOR CONNECTOR</p> <p>13) BATTERY CHARGER INPUT</p> <p>14) FORCE MARGIN SET BUTTON</p> <p>15) OPEN LIMIT LED(GREEN)</p> <p>16) OPEN DRIVE BUTTON (GREEN)</p> <p>17) O/S/C BUTTON (YELLOW)</p> <p>18) SET BUTTON (YELLOW)</p> <p>19) ENGAGE/DISENGAGEMENT CORD</p> <p>20) ENGAGE/DISENGAGEMENT HANDLE EASY ACCESS TRANSMITTER</p> |
|--|---|

PACKAGE CONTENTS

ITEM	QUANTITY
GDO-4 EASYROLLER DRIVE UNIT	1
EASY ACCESS TRANSMITTER EAT-1 (NOT INCLUDED IN SOME MODELS)	1
KEY RING TRANSMITTER PTX-4	2
PTX-4 WALL MOUNT BRACKET	1
ALKALINE BATTERY A23 12V	2
WEIGHT BAR (NOT INCLUDED IN SOME MODELS)	1
SCREW M5x40mm (NOT INCLUDED IN SOME MODELS)	4
HEX NUT M5 (NOT INCLUDED IN SOME MODELS)	4
SPRING WASHER I.D 5 (NOT INCLUDED IN SOME MODELS)	4
SCREW #6x1"	2
PLASTIC WALL PLUGS	2
LOCKING BAR COVERS	2
INSTALLATION MANUAL	1

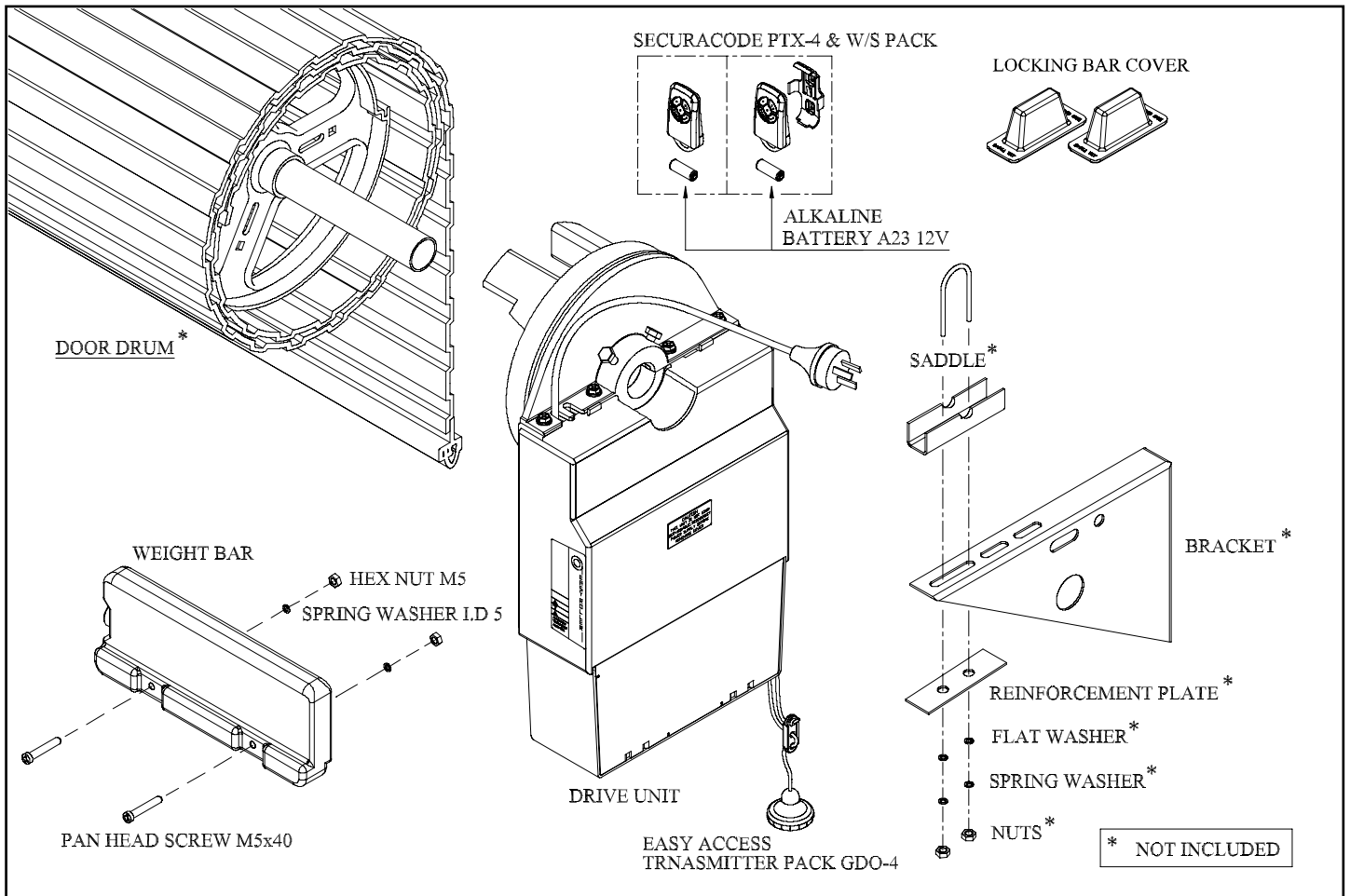

BEFORE INSTALLATION

IMPORTANT SAFETY INSTRUCTIONS FOR INSTALLATION

Warning: Incorrect installation can lead to severe injury. Follow ALL installation instructions.

SIDE ROOM REQUIREMENTS

Fig. 1 shows the minimum side room that is required. The distance between the edge of the door curtain and the inside of the bracket is 85mm minimum, and the distance between the edge of the door curtain and the outside of the bracket is 135mm minimum.

Fig. 2 shows the recommended side room. The distance between the edge of the door curtain and the inside of the bracket should be 110mm, and the distance between the edge of the door curtain and the outside of the bracket is 160mm.

1. CHECK OPERATION OF DOOR

BEFORE BEGINNING THE INSTALLATION OF THE EASY ROLLER AUTOMATIC OPENER CHECK THE OPERATION OF THE DOOR.

The door must be well balanced and be in a reasonable operating condition. You should be able to lift the door smoothly and with little resistance. It should stay open around 900mm to 1200mm above the floor. The door should not stick or bind in the guide tracks. The ideal operational effort in raising or lowering the door should not exceed a force of 10kg (22 lbs.). Make sure that all door locks, ropes, chains etc. are either released, or disabled and remove unnecessary accessories.

2. FIXING OF DOOR WEIGHT BARS

Move the door manually to the mid open position. Place the weight bars equally apart on the bottom rail of the door and secure them with the fasteners provided (**Fig. 3**). Check the operation of the door again. If the door feels heavy it may require extra tension to be added to the door springs. Refer to the door Installation manual from the manufacturer on how to tension the door.

3. LEFT OR RIGHT HAND INSTALLATION

The EasyRoller Automatic Opener can be installed on the left or right hand side of the door (when looking out from the inside of the garage). If your opener is to be installed on the **RIGHT HAND** side of the door then no change needs to be made as the opener is factory set for **RIGHT HAND** installation. If **LEFT HAND** side installation is required the next step is to move the motor wire connector on the control board. The connector plug has to be removed and reconnected to the **LEFT** side of the connector (**Fig. 4**). If you have made an error in selection and wish to install to the **RIGHT HAND** side of the door, then reconnect the connector plug to the **RIGHT** side of the connector (**Fig. 5**).

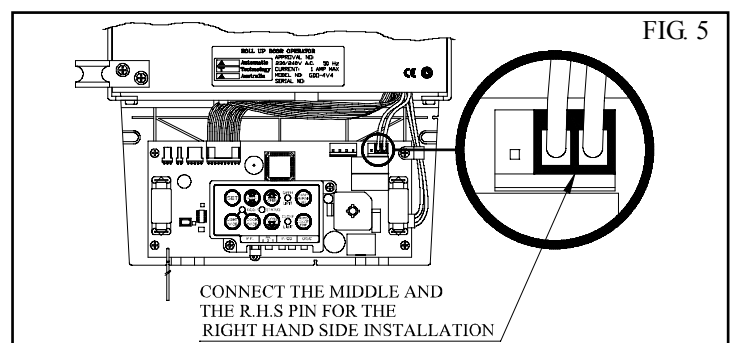
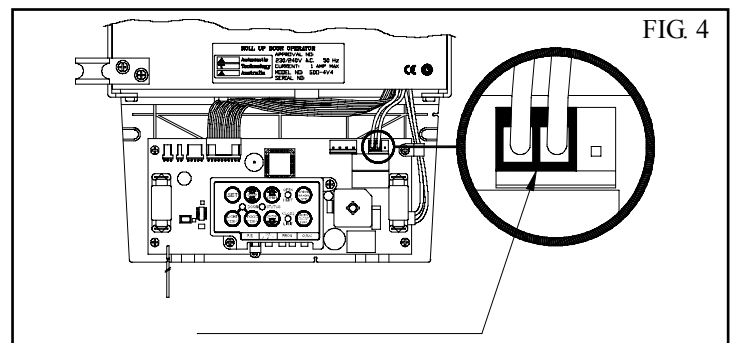
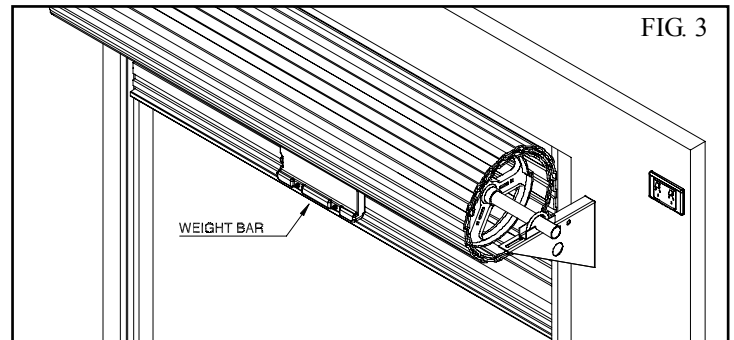
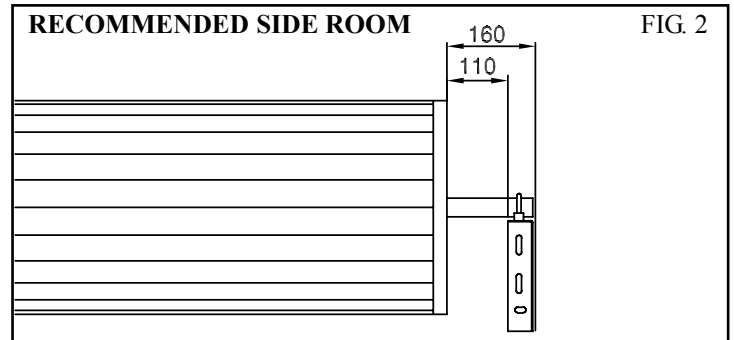
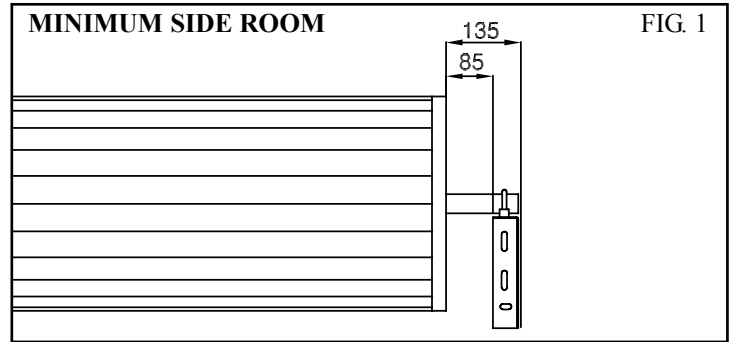

EASY ACCESS TRANSMITTER

THE EASY ACCESS TRANSMITTER

The Easy Access Transmitter is prepared ready for use with the battery pre-installed. Before the transmitter can be operational, the Transmitter Code has to be stored into the openers memory. To store the code please follow the instructions in Step 9.1 on page 15.

REMOVING THE COVER TO REPLACE BATTERY

1. Rotate the cover Clockwise to 'OPEN'
2. Rotate the cover Anti-clockwise to 'CLOSE'

REMOVING THE BATTERY

(Battery Type: 3V Lithium Battery CR1220).

Use a non - metallic object (e.g Pen) to remove the battery.
(see **Fig. 8**)

WARNING

Metallic objects used to remove the battery may **DAMAGE** the the circuit board or the battery.

REPLACING THE BATTERY

Place one side of the battery into the battery holder (**Fig. 9**), then press the battery down firmly until it clicks into a flat position.

Note: The length of the manual release cord is user adjustable simply by sliding the plastic toggle along the cord to achieve the desired length.

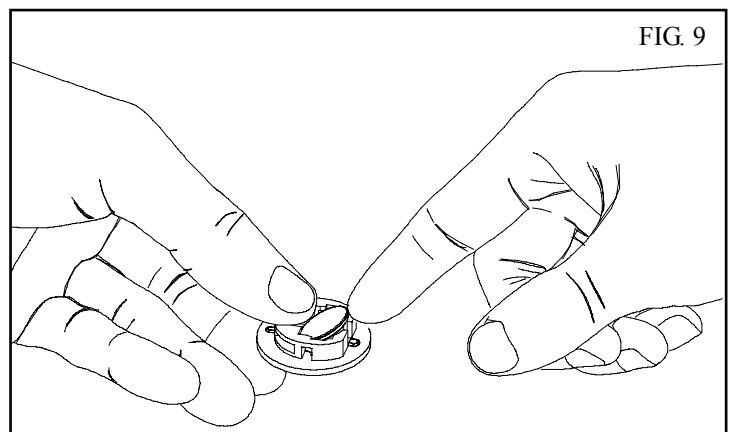
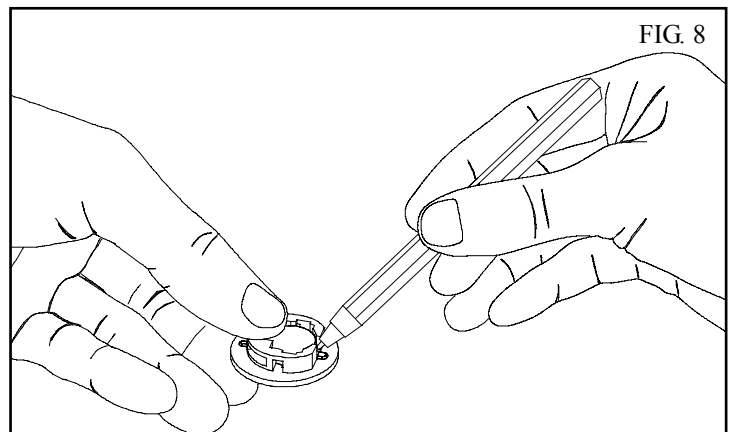
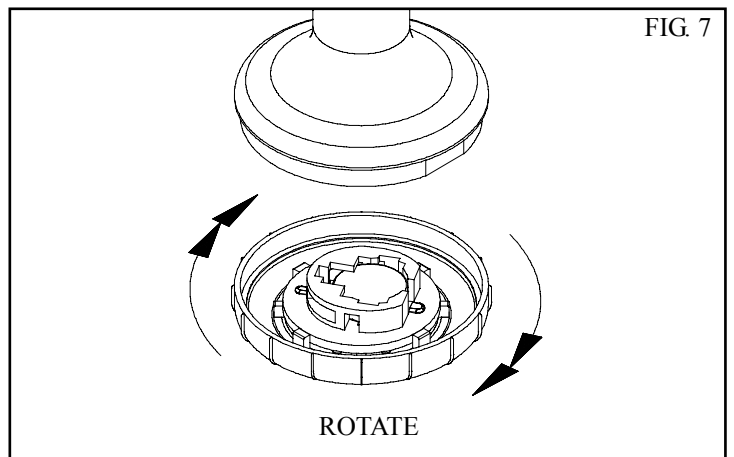
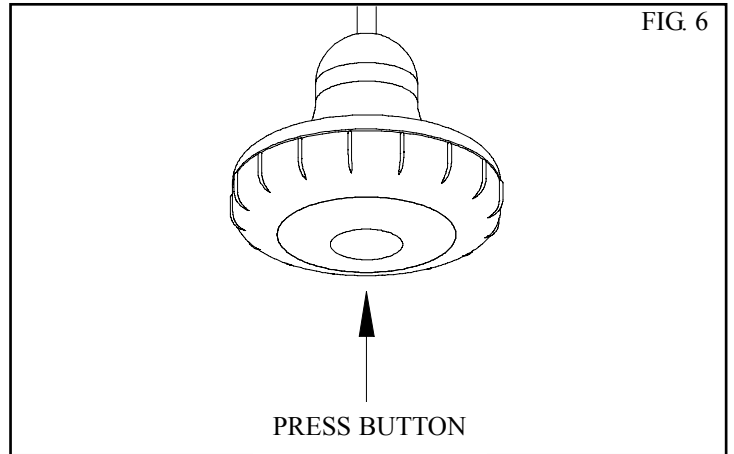

MOUNTING THE OPENER

4. FIXING DRIVE UNIT TO THE DOOR

The EasyRoller Drive Assembly can be fixed to the roll up garage door in a variety of ways. Below we will describe one method of fixing. Make sure there is enough side room (135mm from the end of the door shaft to the wall) to slide the drive assembly onto shaft.

PLEASE NOTE: THE INSTRUCTIONS FOR FIXING THE DRIVE ASSEMBLY TO THE DOOR IS FOR **RIGHT HAND INSTALLATION**.

FITTING DRIVE UNIT TO DOOR

(Fig. 10, Fig. 11, and Fig. 12).

1. Check that the door shaft U bolt is securely tightened on the left hand side of the door.
2. Raise the door and tie a rope around the centre to secure the roll.
3. Support the right hand end of the door with a suitable prop, e.g. step ladder and soft padding to protect door surface.

WARNING: DO NOT ALLOW CHILDREN/PERSONS AROUND THE DOOR AND PROP. SERIOUS PERSONAL INJURY AND/OR PROPERTY DAMAGE CAN RESULT FROM FAILURE TO FOLLOW THIS WARNING.

4. Check that Step 3. was completed. Carefully loosen and remove the right hand door shaft U bolt.
5. Make sure that the door supporting prop is secure. While the door is supported remove the right hand door mounting bracket from wall.
6. Remove the drive assembly from the packaging. Try to rotate the drive gear by pushing on the fork. If the gear does not rotate the manual mode has to be selected. To select pull downward on the string handle, then release slowly. The drive gear should now rotate freely.
7. Slide the drive assembly over the door axle making sure that the fork extends into and over one of the spokes of the door drum wheel.
8. Refit the door mounting bracket to the wall. In some cases the bracket may have to be re-positioned. Re-tighten the door shaft U bolt. Remove door supporting prop and untie the rope from the curtain.
9. Straighten the drive assembly and position as per Fig. 12. Tighten the two locking bolts firmly to secure the Drive Unit.
10. Check the manual operation of the door by raising and lowering the door. The door should run smoothly and not catch on any part of the drive assembly.
11. Adjust the length of the manual release cord so that it can be easily reached by an adult of average height (ie. less than 1.8m tall).

NOTE: After installation, ensure that parts do not extend over public footpaths or roads.

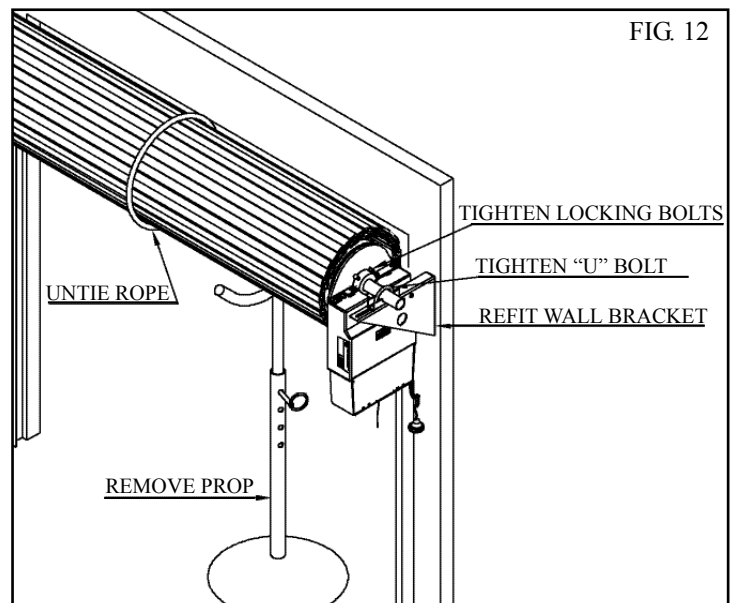
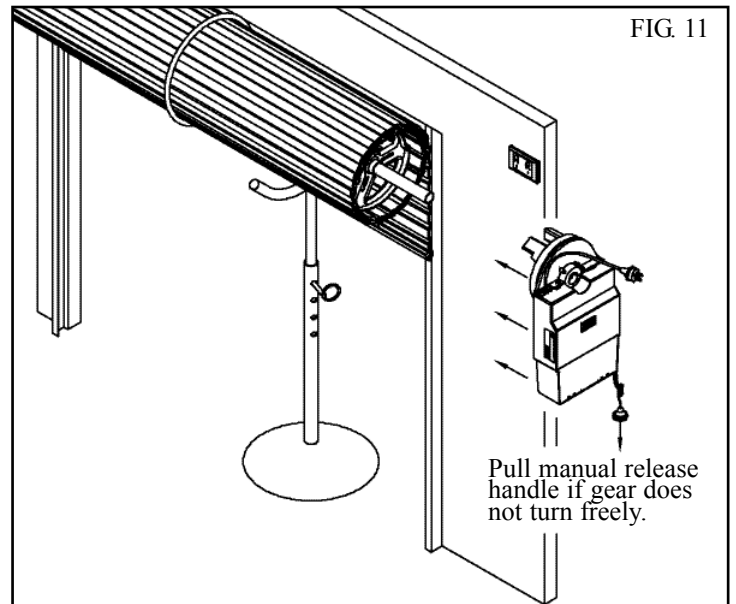
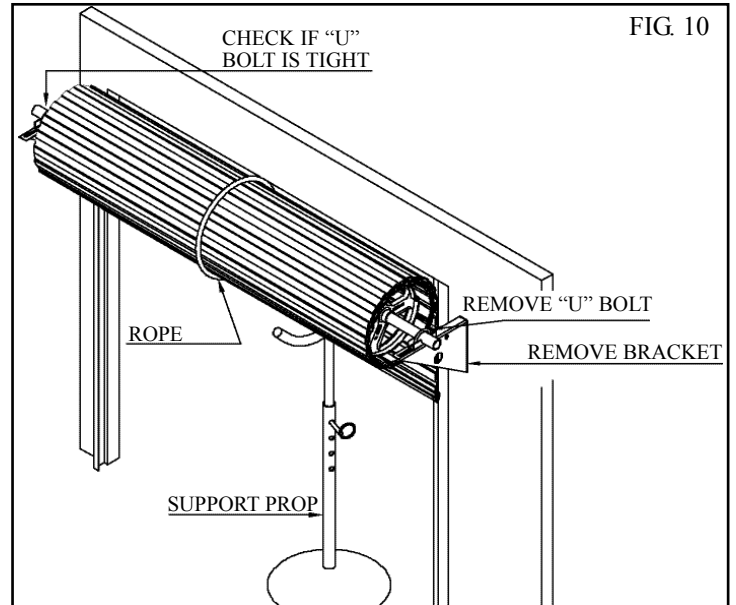

SETTING LIMITS

5. FIXING OF DOOR CURTAIN TO DRUM WHEEL

The door curtain has to be secured to the drum wheel with suitable fasteners.

1. With the door in the fully closed position, mark the curtain (Fig. 13) on both ends of the door.
2. Open door slightly to have access to the marked positions. Secure the curtain to drum wheel using self drilling screws (two on each end). The screws should be at least 90 degrees apart (Fig. 13).

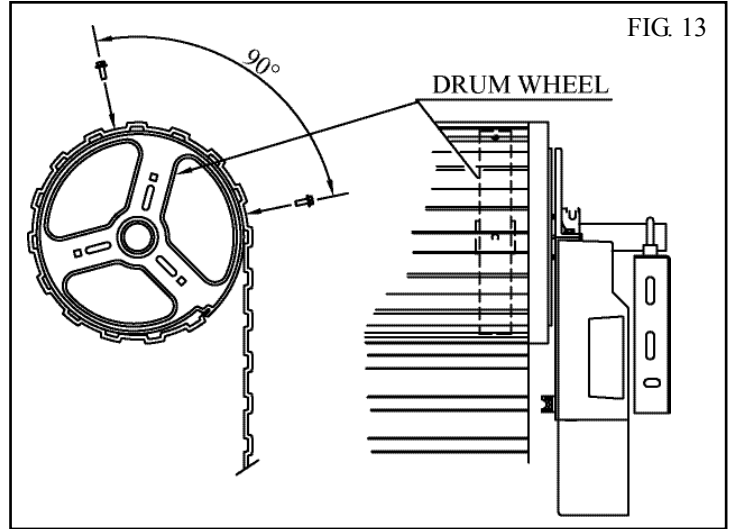

FIG. 13

6. SETTING DOOR TRAVEL LIMITS POSITIONS - METHOD ONE - VIA THE CONTROL PANEL

IMPORTANT NOTE: The O/S/C button will not function until the open and close limits positions are set.

6.1 SETTING LIMITS POSITIONS

1. With the drive assembly in manual mode (Fig. 13) move the door up by hand to an approximately mid open position.
2. Re-engage the drive gear to the door by pulling down on the string and then releasing (Fig. 14).
3. Remove the light diffuser as per Fig. 14. Plug in the opener and turn the power on.
4. Press the Close button (Fig. 15), the door will start closing. Release the button once you have reached your desired closed limit position.
5. Press the Set button (Fig. 15). This action will store into memory the closed limit position.
6. Press the Open button (Fig. 15), the door will start opening. Release the button once you have reached your desired opened limit position.

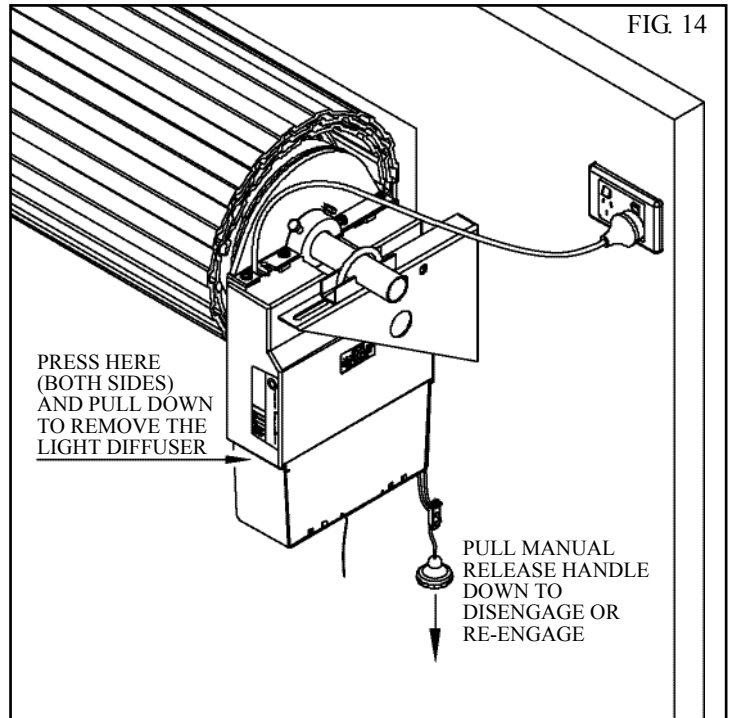

FIG. 14

IMPORTANT WARNING: Please be aware that the garage door will start closing automatically once step 7 is performed. The door will also automatically re-open after fully closing with a small pause between the cycles.

7. Press the Set button (Fig. 15). This action will store into memory the open limit position. The door will now automatically close to its limit position then fully open to calculate the safety obstruction forces (ISS). Please be aware of the above warning. The opener can now be operated from the O/S/C Button.

6.2 RESETTING DOOR LIMIT POSITIONS

The door travel limit positions can be deleted for new positions by the following steps below:

1. Press and hold the Close button (Fig. 15) for six (6) seconds until you hear three beeps and the red Close Limit LED starts to flash. Release the button.
2. Follow STEP 6.1 1 to 7 to set new travel limit positions.

Go to STEP 8 and test the Safety Obstruction Force.

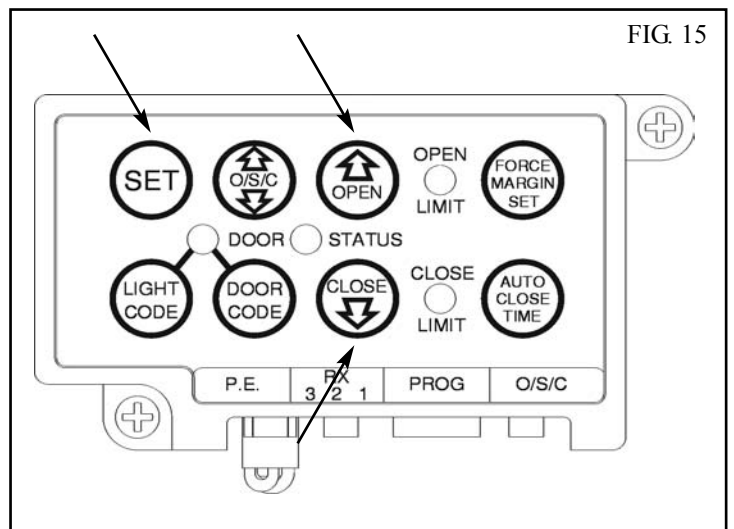

FIG. 15

SETTING LIMITS

7. SETTING DOOR TRAVEL LIMIT POSITIONS – METHOD TWO - VIA THE REMOTE CONTROL

IMPORTANT NOTE: The O/S/C button will not function until the open and close limits position are set.

7.1 SETTING LIMITS

1. With the drive assembly in manual mode (Fig. 14) move the door up by hand to an approximately mid open position.
 2. Re-engage the drive gear to the door by pulling down on the string and then releasing (Fig. 14).
 3. Remove the light diffuser as per Fig. 14. Plug in the opener and turn the power on.
 4. Press and hold the Door Code button (Fig. 16).
 5. Press button 1 (Fig. 17) on the transmitter for two seconds. Release and pause for two seconds. Press the same button again on the transmitter for two seconds.
 6. Release the Door Code button.
 7. With the drive assembly in manual mode (Fig. 14) move the door up by hand to an approximately mid open position.
 8. Re-engage the drive gear to door by pulling down on the string and then releasing (Fig. 14).
 9. Press button 4 (Fig. 17), the door will start closing, release the button once you are 1 to 2 cm from your desired closed limit position. Press button 3 (Fig. 17) for two seconds then release.
 10. Press button 4, each press will enable you to inch the door to your desired closed position.
 11. Once you are happy with the position press button 2 (Fig. 17), this action will store into memory the closed limit position.
 12. Press button 1 (Fig. 17), the door will start opening. Release the button once you are 1 to 2 cm from your desired open limit position. Press button 3 for two seconds then release.
 13. Press button 1. Each press will enable you to inch the door to your desired closed position.
- IMPORTANT WARNING:** Please be aware that the garage door will start closing automatically once step 14 is performed. The door will also automatically re-open after fully closing with a small pause between the cycles.

14. Once you are happy with the position press button 2, this action will store into memory the open limit position. The door will now automatically close to its limit position then fully open to calculate the safety obstruction forces (ISS). Please be aware of the above warning.

7.3 RESETTING DOOR LIMITS POSITIONS

The door travel limit positions can be deleted for new positions by the following steps below:

1. Press and hold the Close button (Fig. 16) for six (6) seconds until you hear three beeps and the red Close Limit LED starts to flash. Release the button.
 2. Follow STEP 7.1 1 to 14 to set new travel limit positions.
- Important:** There is no need to re-code the transmitter used for setting the limit positions. After the limits are set the transmitter will automatically reset to normal operation.

Go to STEP 8 and test the Safety Obstruction Force.

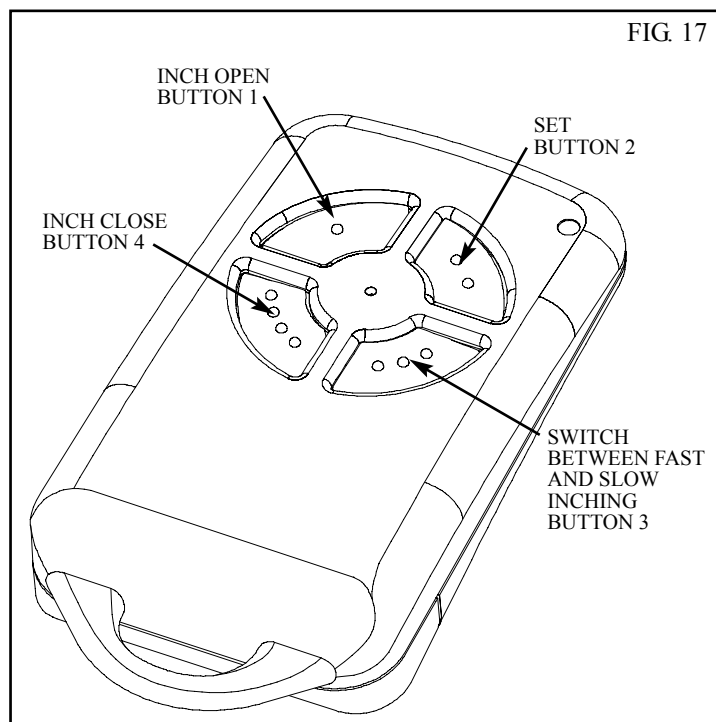
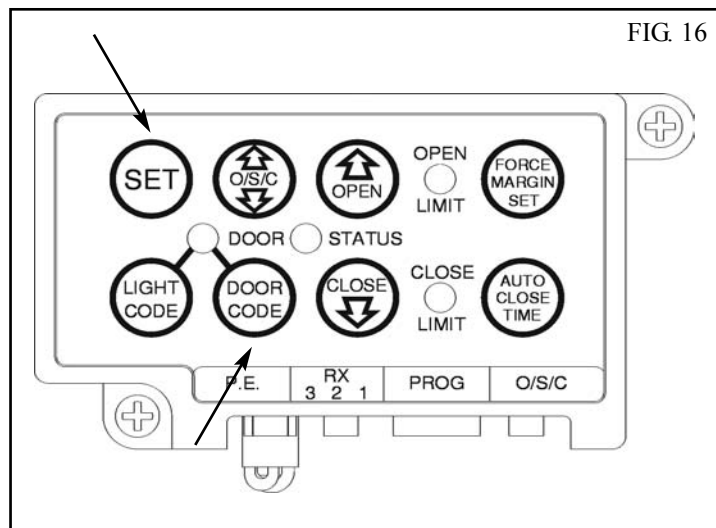

SETTING SAFETY OBSTRUCTION FORCE

8. SAFETY OBSTRUCTION TEST

Please take care when testing the Safety Obstruction Force. Excessive forces may cause **SERIOUS PERSONAL INJURY** and/or property damage can result from failure to follow this warning. The test below should be repeated at regular intervals (approximately every two months).

8.1 TESTING CLOSE CYCLE

1. Open the door by pressing the Yellow O/S/C button (Fig. 18).
2. Place a length of timber approximately 50mm high on the floor directly under the door (Fig. 19).
3. Press the Yellow O/S/C button to close door. The door should strike the object and start to re-open.
4. Press again to close the door. When the door reaches half the closing distance, grab the bottom rail of the door firmly, the door should re-open. If the door stops on the obstacle and fails to reopen, readjust and set the close limit lower (see Step 6.2). Re-test as per Step 8.1 after you have adjusted the close limit.

IMPORTANT WARNING: If the test fails, there may be a problem with the door, discontinue use, put the door into manual operation and call for service.

8.2 TESTING OPEN CYCLE

1. Close the door by pressing the Yellow O/S/C button.
2. Press again to open the door. When the door reaches half the opening distance, grab the bottom rail of the door firmly, the door should stop.

ADJUSTING SAFETY OBSTRUCTION FORCE

The Safety Obstruction Force is calculated automatically and set in memory on the EasyRoller. It is usually not necessary to adjust the Safety Obstruction Force. The only time the force may need to be increased is due to environmental conditions, for example, windy or dusty areas, and areas with extreme temperature changes.

8.3 TO INCREASE FORCE PRESSURE

1. Press and hold the Force Margin Set button (Fig. 18)
2. While holding down the Force Margin button, press the Open button (Fig. 18). Each press increases the force margin. The Open Limit LED will illuminate each time the Open button is pressed. Each press increases the force margin. Test the force as per step 8.1 and 8.2. If the Open Limit LED flashes continuously when the open button is being pressed, this indicates that the maximum force pressure setting has been reached.

8.4 TO DECREASE FORCE PRESSURE

1. Press and hold the Force Margin Set button (Fig. 18).
2. While holding down the Force Margin button, press the Close button (Fig. 18). Each press decreases the force margin. The Close Limit LED will illuminate each time the close button is pressed. Test the force as per step 8.1 and 8.2. If the Close Limit LED flashes continuously when the Open button is being pressed, this indicates that the maximum force pressure setting has been reached.

8.5 TO RECALL FACTORY SET FORCE

1. While holding down the Force Margin Set button (Fig. 18) press the SET button (Fig. 18) for two (2) seconds.
2. Release both buttons. The default setting should now be recalled.

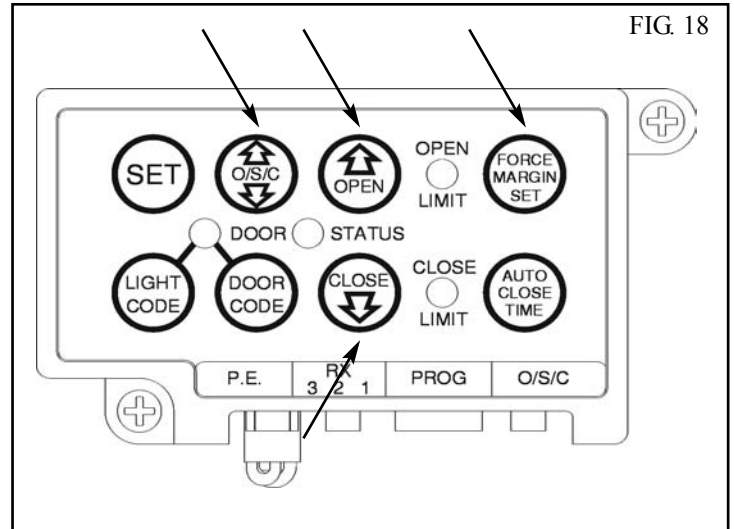

FIG. 18

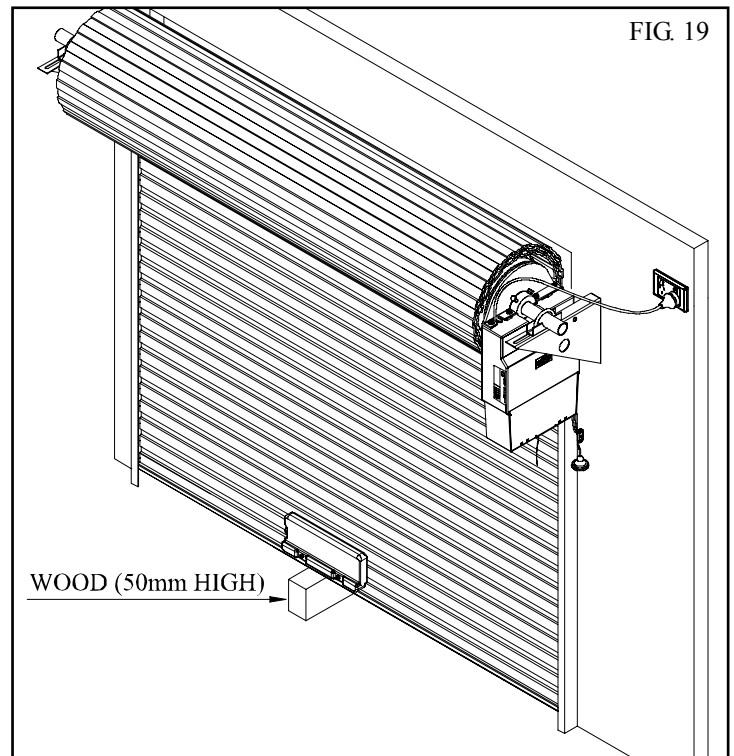

FIG. 19

IMPORTANT NOTE:

After installation ensure that the opener stops or is prevented from opening when the door is loaded with a mass of 20kg fixed centrally at the bottom edge of the door.

CODING TRANSMITTERS

9. SETTING TRANSMITTERS CODES

Make sure to connect the battery to the transmitters. The memory in the openers receiver can store up to 23 different remote control transmitters.

9.1 STORING THE TRANSMITTERS CODE

1. Press and hold the Door Code button (**Fig. 20**).
2. Press the button (one of four) on the transmitter you would like to use to control the door for two seconds, pause for two seconds. Press the same button again on the transmitter for two second.
3. Release the Door Code button.
4. Press the transmitter button to test if it operates the door.

9.2. SETTING THE TRANSMITTER TO OPERATE THE COURTESY LIGHT

The transmitter can be programmed to operate the courtesy light on the door opener.

1. Press and hold Light Code button (**Fig. 21**).
2. Press the button on the transmitter you would like to use to switch on the light for two seconds, pause for two seconds. Press the same button again on the transmitter for two seconds.
3. Release all buttons to store the transmitter in memory.
4. Press the transmitter button to test if it switches on the light.

9.3. SETTING THE TRANSMITTER TO OPERATE PET (PEDESTRIAN) MODE

1. Press and hold Door Code button and the Close button (**Fig. 21**).
2. Press the button on the transmitter you would like to use to control pedestrian mode for two seconds, pause for two seconds. Press the same button again on the transmitter for two seconds.
3. Release all buttons to store the transmitter in memory.
4. Press the transmitter button to test if it operates the pedestrian mode.

To change the default pedestrian door opening position, refer to Item 15 on page 18.

9.4. SETTING THE TRANSMITTER TO OPERATE VACATION MODE

1. Press and hold Light Code button and the Close button (**Fig. 21**).
2. Press the button on the transmitter you would like to use to control vacation mode for two seconds, pause for two seconds. Press the same button again on the transmitter for two seconds.
3. Release all buttons to store the transmitter in memory.
4. To test, press and hold the transmitter button set for vacation mode for five seconds to set Vacation Mode.

To reset Vacation Mode press the same button for two seconds. Please note that when vacation mode is activated all stored transmitters will be locked out. This mode can only be deactivated by a transmitter which has been stored to activate this mode.

FIG. 20

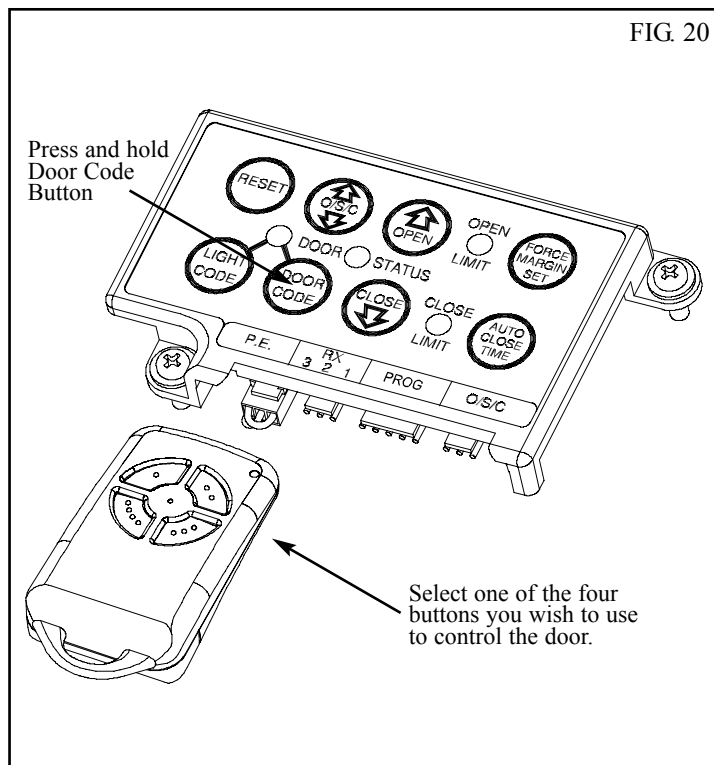
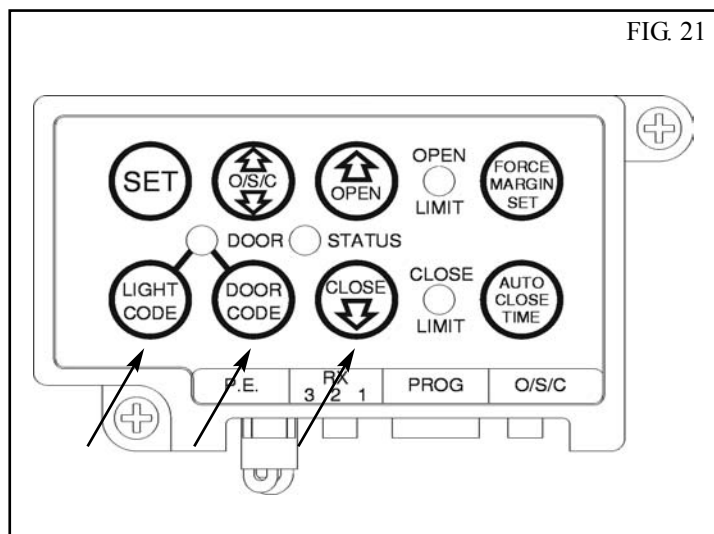

FIG. 21



CODING TRANSMITTERS

10. STORING TRANSMITTER(S) FROM A REMOTE LOCATION

Using this method you don't need to have access to the control panel on the Door Opener. However, you do need a transmitter that is pre coded to the controller's receiver.

IMPORTANT NOTE: The Door or Courtesy Light must be activated when the step below is performed. The moving Door or Light switching on is to confirm from a remote location that, the correct button was pressed, and the transmitter is in range of the Opener.

1. Take any pre-coded transmitter. Press the button for the function you require until the door is activated and release.
2. Then using a small needle press and hold firmly for two seconds through the Coding Hole (**Fig. 22**)
3. Within 10 seconds take the additional transmitter you wish to code.
4. Press the button (one of four) on that transmitter you would like to use to control the door for two seconds, pause for two seconds. Press the same button again on the transmitter for two second, the button should now be recorded.
5. Wait for 10 seconds and then press the recorded transmitter button to see if it operates the door.

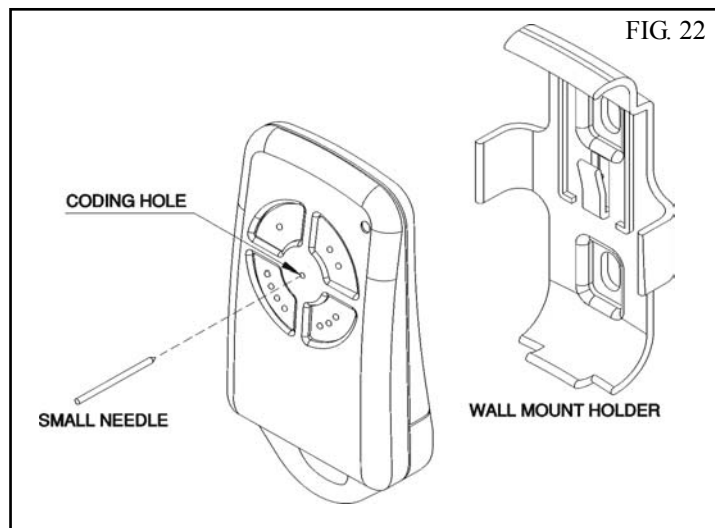

11. DELETING PROGRAMMED CODES

11.1 DELETING A STORED TRANSMITTER CODE

1. Select the transmitter you want to delete.
2. Press and hold the Door Code button (**Fig. 23**).
3. Press the transmitter button you would like to delete for two seconds. Pause for two seconds. Press the transmitter button again for two seconds.
4. Release the Door Code button. The code should now be deleted. Confirm this by pressing the transmitter button, the door should not respond.

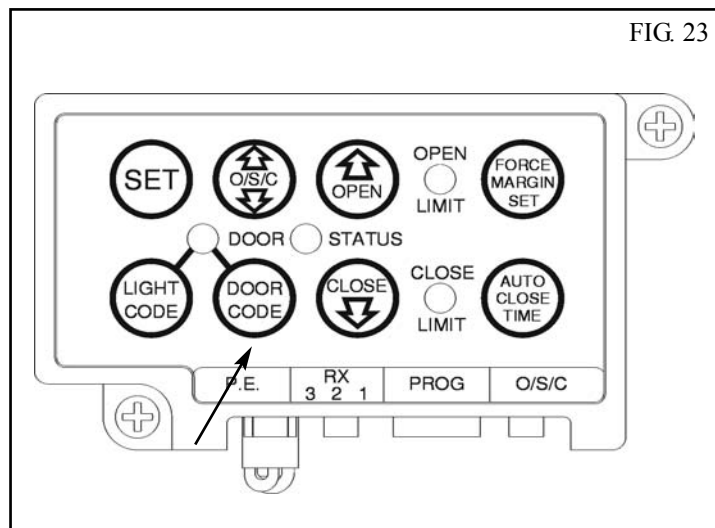

11.2 DELETING ALL STORED TRANSMITTER CODES

1. Turn the Power Off to the Opener.
2. Press and hold the Door Code button (**Fig. 23**).
3. Turn the Power On again, while holding the Door Code button. The Open Limit, Close Limit and Door Status LED's will illuminate for about five seconds. These LED's will turn Off and the Coding LED will illuminate. Release the Door Code button. All the stored codes including the Courtesy Light codes should now be deleted. Confirm this by trying to operate the door by pressing the transmitters previously used to control the door, the door should not respond.

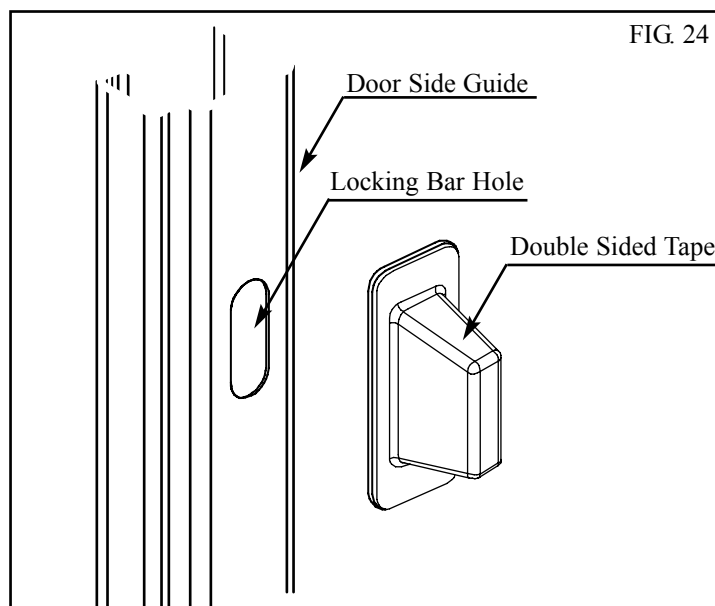

12. INSTALLING LOCKING BAR COVERS

To protect against entrapment of fingers etc. inserted into side guides – remove the protective backing of the double sided tape and install the locking bar covers over the holes in each side guide (door guide track.)

PE BEAM AND AUTO CLOSE

12. FITTING THE SAFETY PHOTO ELECTRIC BEAM SENSOR (OPTIONAL)

Locate the Photo Electric Beam (P.E.) normally closed contact type in a strategic location within doorway. We recommend 150mm above the floor level and as close as possible to the door opening, inside the garage. Remove shunt from P.E. connector (Fig. 25) and connect the plug from the P.E. wiring harness to P.E. connector (Fig. 26). The wiring diagram is for Model PHBE (Order Code 90214).

Make sure to align the beams correctly. Follow the manual supplied with the Photo Electric Beam.

WARNING; When using Auto Close Mode and P.E. beams, the doorway must be clear of all obstructions and persons at all times. The location of the beam and manner in which it is installed might not give safety protection at all times. Check to make sure that the height of the beam and type used give maximum protection possible.

13. SETTING OF AUTO CLOSE TIME

IMPORTANT NOTICE: IT IS COMPULSORY TO INSTALL A PHOTO ELECTRIC BEAM BEFORE USING THE AUTO CLOSE MODE.

The Auto Close timer will only start after the Photo Electric Beams (P.E.) path is broken and the auto close time has been set. If the P.E. path is not broken the door will remain open till the path is broken. If the Door Opener incurs an obstruction (not from the P.E.) while closing the door will re-open and not auto close until the path of the P.E. beam is broken again.

SETTING AUTO CLOSE TIME

1. Press in and hold the Auto Close Time button (Fig. 25).
2. While holding in the Auto Close Time button, press the Open button (Fig. 25). Each press of this button will add one second to the auto close delay time.
3. To decrease the delay time follow Step 1 and press the Close button. Each press will deduct one second from the auto close time.
4. Press the O/S/C button (Fig. 25) or transmitter to open the door. When the door is fully opened the Open Limit green LED will flash to indicate that the auto close mode is in operation. Break the path of the P.E. Beam momentarily, this will initialise the auto close mode. When the door reaches the fully opened position, the door will pause for the set auto close time and start to auto close.

14. MANUAL RELEASE

To switch the opener to manual mode simply pull the red manual release handle down and release. To re-engage the opener repeat the above action.

Note: The door may move uncontrollably if the spring tension is weak or not set properly or the door is unbalanced.

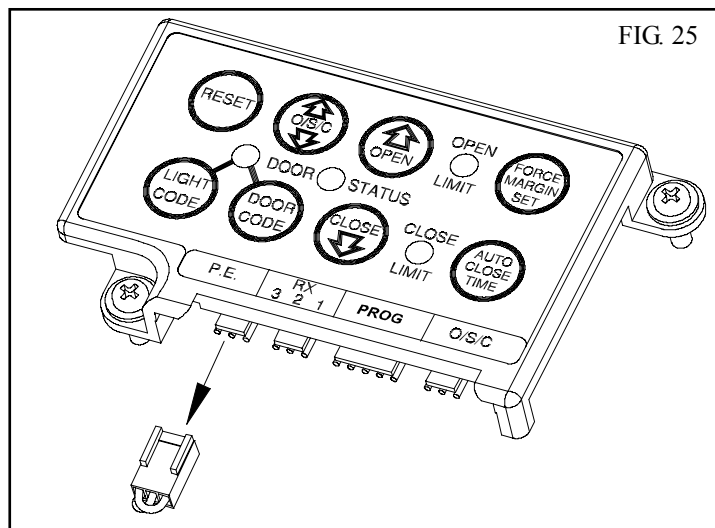

FIG. 25

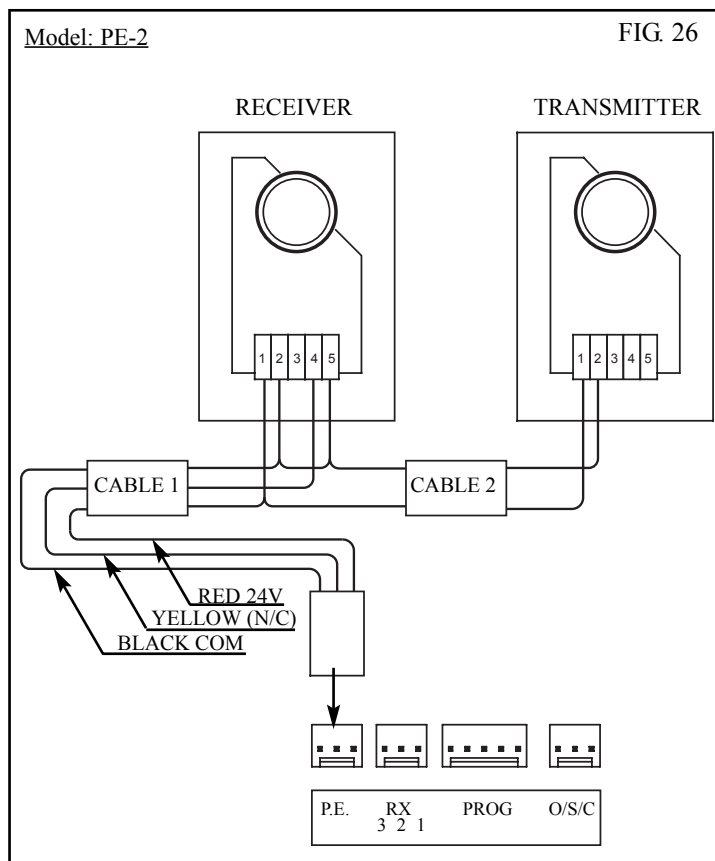

FIG. 26

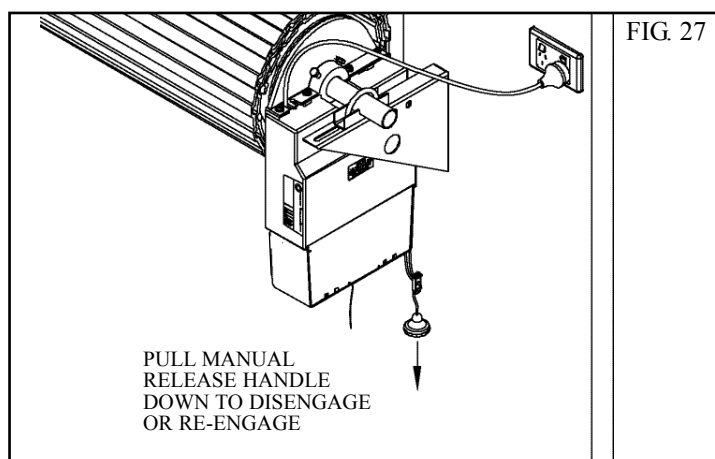

FIG. 27

FINAL SET UP

15. SETTING OF COURTESY LIGHT TIME

The preset courtesy light time on the door opener is 3 minutes. This time can be changed by the following:

1. Press in and hold both the Auto Close Time button and Force Margin Set button (**Fig. 27**).
2. While holding in the two buttons, press the Open button (**Fig. 27**). Each press of the button will add 10 seconds to the light time.
3. To decrease the time follow Step 1 and press the Close button (**Fig. 27**). Each press will deduct 10 seconds from the light time.
4. To recall the factory set default light time press in and hold together the Auto Close Time button, the Force Margin Set button and the Set button for about 2 seconds. Release all buttons, the factory set default of 3 minutes will be recalled.

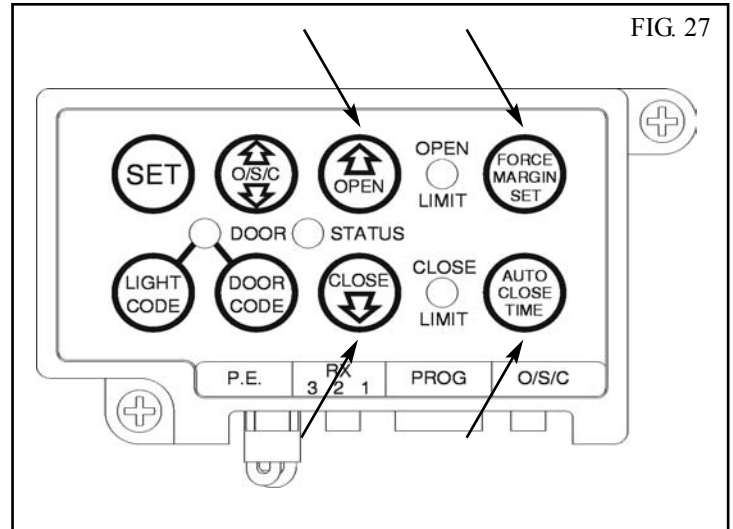

16. SETTING THE PET MODE DOOR OPENING POSITION.

The default PET (Pedestrian) position is about 1/4 turn of the door drum above the closed position. The PET mode status is indicated by both the Open and Close Limit LED's being illuminated. The default position can be changed by the following:

1. Make sure the door is in the closed position. Press and hold the Open button for six (6) seconds (**Fig. 28**), you should hear three beeps and the Open and Close LEDs will flash rapidly.
2. Press the Open and Close buttons (**Fig. 28**) to move the door to your required new pet open door position.
3. Press the Set button (**Fig. 28**) to record the new position.

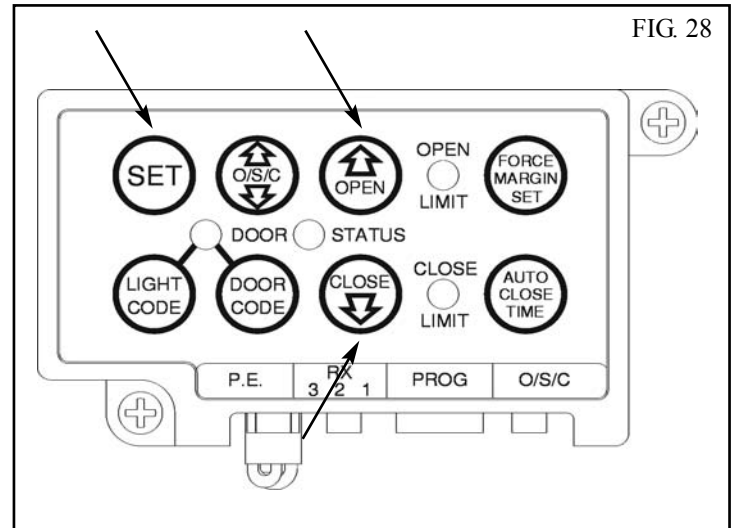

The Pet mode is activated from a transmitter button coded to that function. When activated the door drives to the preset position from either above or below. If the Pet button is pressed while the door is moving the door will be stopped. If the Pet button is pressed when the door is in the Pet position, then the door will be closed. No auto close is enabled.

17. INSTALLATION OF WALL MOUNTED TRANSMITTER HOLDER

1. Mount the holder in a location out of reach of children (at least 1.5m from the floor) and convenient to the customer. (**Fig. 29**). Make sure the door is visible from this location.
2. The transmitter can be easily clipped in and removed from the holder as required.
3. To set the transmitter codes refer to Step 9.

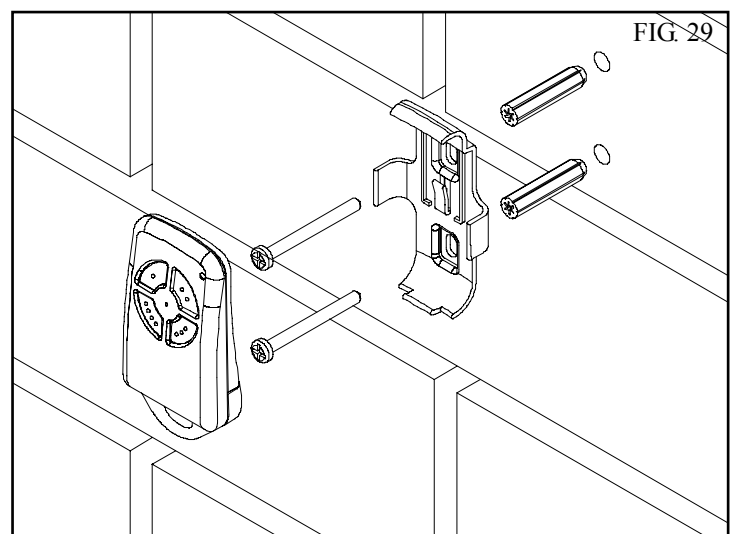

18. RE-INITIALISING THE OPENER

To re-initialise the opener press and hold the Set Button for two (2) seconds, the beeper will sound once. The door will start to move and re-calculate force margins. The door can move between the open and close limit positions up to four (4) times (depending on the position of the door and the power up condition). A single beep will be heard once the initialisation is complete. The door is now ready for use.

PARAMETERS

DOOR STATUS INDICATORS

DOOR OPENER STATE	OPEN LED GREEN	CLOSE LED RED	DOOR STATUS LED YELLOW	BEEPER
OPEN	ON			
CLOSE		ON		
OPENING	FLASHING			
CLOSING		FLASHING		
DOOR TRAVEL STOPPED	FLASHING	FLASHING		
DOOR OBSTRUCTED WHEN OPENING	FLASHING			
DOOR OBSTRUCTED WHEN CLOSING		FLASHING		BEEPS WHILE DOOR IS MOVING
DOOR OVERLOADED	ALTERNATING FLASHES	ALTERNATING FLASHES		
DOOR IN OPEN POSITION WITH AUTO CLOSE MODE SELECTED	ONE SECOND FLASHES			
MAINS POWER INTERRUPTED	RAPID FLASHES			

BUTTONS	FUNCTION
O/S/C	Opens/Stops/Closes the door
Door Code	Codes a transmitter button for O/S/C function
Light Code	Codes a transmitter button for light function
Door Code + Close	Codes a transmitter button for pet (pedestrian) function
Light Code + Close	Codes a transmitter button for vacation function
Force Margin Set + Open	Increases the obstruction force margin setting
Force Margin Set + Close	Decreases the obstruction force margin setting
Force Margin Set (then) Set	Reloads the factory set default obstruction force margin setting
Auto Close Time (then) Open	Increases the auto close delay time
Auto Close Time (then) Close	Decreases the auto close delay time
Auto Close Time (then) Set	Reloads the factory set default auto close delay time
Force Margin Set + Auto Close Time (then) Open	Each press of the open button increases the light time by 10 secs.
Force Margin Set + Auto Close Time (then) Close	Each press of the open button decreases the light time by 10 secs.
Force Margin Set + Auto Close Time (then) Set	Reloads the factory set default light time
Close for 6 Secs	Clears the door limits set positions. Limits then need to be reset.
Open for 6 Secs. + Door in Closed Position	Enters pet (pedestrian) position mode.
Set (then power on) & hold until all LEDs are off	Deletes control parameters excluding transmitter storage memory.
Door Code (then power on) & hold until all LEDs are off	Deletes all transmitter storage memory.
Set for 2 sec.	Re-initialises the Opener to re-calculate force margins

SPECIFICATIONS AND DEFAULT SETTINGS

FACTORY DEFAULT SETTINGS

	DEFAULT	STEP	MAXIMUM
MAXIMUM MOTOR RUN TIME	30 Secs.	—	—
COURTESY LIGHT TIME	3 Mins.	10 Secs.	4 Mins.
OBSTRUCTION FORCE MARGIN	4	1	14
AUTO CLOSE TIME	0 Secs.	1 Sec.	4 Mins.

TECHNICAL SPECIFICATIONS

INPUT VOLTAGE:	230V- 240V AC 50Hz (Other voltages available upon request e.g. 110V AC 60Hz)
TRANSFORMER PRIMARY VOLTAGE:	230V / 240VAC
SECONDARY VOLTAGE:	24V AC 100 VA
CONTROLLER VOLTAGE:	24V DC
MAXIMUM DOOR OPENING:^{1,2} WIDTH:	5100mm
HEIGHT:	3100mm
RATED LOAD:	200N
OPENER OPENING/CLOSING LIMITS TRAVEL:	3.5 Turns of Door Drum Wheel
OPENER MAXIMUM OPENING/CLOSING RUN TIME:	30 Secs.
RECEIVER TYPE:	UHF 433.92 MHz. AM Receiver
RECEIVER CODE STORAGE CAPACITY:	23 x 4 Button Transmitter Codes
TRANSMITTER FREQUENCY:	433.92 MHz
CODING TYPE:	Code Hopping
No. of CODE COMBINATIONS:	Over 4.29 Billion Random Codes
CODE GENERATION:	Non-linear Encryption Algorithm
PTX-4 TRANSMITTER BATTERY:	A23 Alkaline 12 Volts
EAT-1 TRANSMITTER BATTERY:	CR1220 Lithium 3 Volts
MOTOR TYPE:	Permanent Magnet Direct Current
MOTOR VOLTAGE:	24V DC
GLOBE:	Festoon Type - 15w 24V DC

Note:

1. The maximum continuous curtain domestic roll up door opening that the EasyRoller can be installed on is 5100mm wide by 3100mm high. The door must be well balanced. A person should be able to lift the door up manually with very little effort in case of an emergency.
2. Intermittent operations may occur in areas which experience very strong winds. The strong wind puts extra pressure on the door and tracks which may in turn trigger the safety obstruction detection system intermittently.

TROUBLE SHOOTING

SYMPTOM	POSSIBLE CAUSE	REMEDY
Door will not operate.	Mains power not switched on. Door is obstructed. Door is locked or motor jammed. Door tracks/hardware damaged.	Switch on mains power. Remove obstruction. Unlock door or remove jam. Door requires service/repair by qualified technician.
Door starts to close but automatically reverses to open position.	Adverse weather conditions (wind or cold) causing door to stiffen and become tight in the tracks. Possible obstruction in the doorway.	Increase force margin setting and/or re-initialise the door. See Step 8 on page 11. Remove obstruction.
Door operates from drive unit (O/S/C) button but not from transmitter.* See note.	Transmitter code not stored in memory. Flat Battery.	Code transmitter in to openers memory. Refer Step 9.1 on page 15. Replace battery - A23 Alkaline 12V.
Door will not close fully.	Door limits positions need to be reset.	Reset limits positions. See Step 6 Page 12.
Door will not open fully.	Door limits positions need to be reset.	Reset limits positions. See Step 6 Page 12.
Courtesy light not working.	Globe blown.	Replace globe - festoon type 15W 24V DC.
Globe keeps blowing.	Incorrect globe voltage - must be 24V DC.	Replace globe - festoon type 15W 24V DC.
Auto close not working.	PE Beam or wiring faulty PE Beam not aligned correctly. PE Beam is obstructed. Door obstructed when closing. Auto close time not set. Auto close mode not set.	Repair PE Beam or replace wiring. Re-align optics. Remove obstruction from the path of PE. Remove obstruction. See Step 13 on page 17. See Step 13 on page 17.

***Please Note:** Some areas may be prone to excessive radio interference brought on by devices such as cordless telephones, wireless stereo headphones and baby monitors. It is possible that these devices could cause a degree of interference such as to greatly reduce the range of the transmitter. In such an instance please contact your ATA dealer for an alternative frequency replacement kit. As this is not a warrantable situation but an environmental issue charges may apply for the changeover.

DATE	MAINTENANCE PERFORMED BY	SIGNATURE	AMOUNT	INV. No.

Please Note: Failure to maintain your garage door may void the warranty for your garage door opener.

SPARE PARTS LIST

ITEM NO.	DESCRIPTION	ORDER CODE
1	CLAMP ASSY GDD-4	01600
2	CLAMP	16000
3	CORD LABEL	13380
4	INTERNAL GEAR	16020
5	HEX. HEAD SCREW M8x25	10110
6	CLAMP WASHER	11180
7	RETAINING RING STW 45	10650
8	GEARED MOTOR ASSY 10	00368
9	HELICAL GEAR 85075 CX	04080
10	E CIRCLIP D1500 0080	10810
11	PINION 122523	04162
12	SELF LOCK EXT WASHER 706-2	10738
13	GEARBOX COVER 85	04221
14	MOTOR BASE	04430
15	BUTTON HEAD SCREW W/PATCH M6x16	10022
16	DISENGAGEMENT CAP	04410
17	CAM	04870
18	SPECIAL WASHER	10620
19	DISENGAGEMENT SHAFT	16140
20	DISENGAGEMENT LEVER	16400
21	CAM SPRING	12391
22	PLASTIC BASE G-4V4 ASSY	01722
23	Q-G ASSEMBLY V3	01730
24	QUAD 101 BOARD	01692
25	GRAY 103 BOARD	01693
26	HELICAL GEAR 26075 CX	04094
27	INDEX SHAFT 32 SLOTS	16350
28	LIMITS WHEEL	16358
29	LIMITS HOLDER	16363
30	TRANSFORMER TDB-100-03 KIT	02020
31	E CIRCLIP D1500 0040	10830
32	Q-G 101 HARNESS CX ASSY	01790
33	INDEX GEAR 1225	16354
34	CHOPPER CLIP	04960
35	DISENGAGEMENT SPRING	12360
36	STRING GUIDE	16420
37	TRANSFORMER 100VA-05544 TDB-100-03	05544
38	POWER CORD 15M W2PIN+1 RING	14150
39	CORD GRIP GRIMMET SB-6R-3	05600
40	TERMINAL BLOCK 500/02DS 2 POS	05421
41	CAP POLYFILM 0.1UF K X2 275 VAC	07575
42	WASHER CUP 55.5x7.2x7Hx1T	11168
43	HEX HEAD SCREW M6x55	10263
44	PAN SERRATION HEAD SCREW M4x12	10380
45	PAN HEAD SCREW M4x12	10310
46	SERRATION HEAD SCREW W/WASHER M4x12	10381
47	TAPTITE SCREW 'P' M4x6	10582
48	TAPTITE SCREW 'P' BLACK ZNC M3x16	10550
49	HEX NUT W/INT TOOTH WASHER M5	10881
50	SPRING WASHER I.D 6	10960
51	WASHER RUBBER 58.8x8.8x1	04888
52	FLAT WASHER I.D 5	11050
53	IDENTITY LABEL	13592
54	CONTR'OL BOARD CB-7 V-5.03	00842
55	BOARD SUPPORT	16220
56	BOARD COVER	16241
57	CONTR'OLS LABEL	13583
58	GLOBE 24V/15W 15x44	05440
59	CABLE CLAMP ACC-1.5 (3/16")	11750
60	TAPTITE SCREW 'P' M4x10	10570
61	EASY ACCESS TRANSMITTER PACK GDD-4	01237
62	LITHIUM BATTERY 3V	13020
63	MAIN COVER	16250
64	LIGHT DIFFUSER	05120
65	LOGO LABEL LEFT	13390
66	LOGO LABEL RIGHT	13530
67	WARNING LABEL	13710
68	HEX SERRATION HEAD SCREW M6x16	10170
69	SECURACODE PTX-4 & W/S PACK	01220
70	TRANSMITTER GBR PTX-4	01210
71	ENCLOSURE GBR PTX SP	05203
72	TAPTITE SCREW 'P' M2x8	10564
73	TRANSMITTER RBR PTX-4	01211
74	ENCLOSURE RBR PTX SP	05204
75	PTX HOLDER	05196
76	ALKALINE BATTERY A23 12V	13030
77	PLASTIC WALL PLUG PACK	01479
78	COVER WITH D/S TAPE	71040

WHEN ORDERING SPARE PARTS
PLEASE QUOTE THE ORDER
CODE NUMBER TO YOUR YOUR
INSTALLER/DISTRIBUTOR

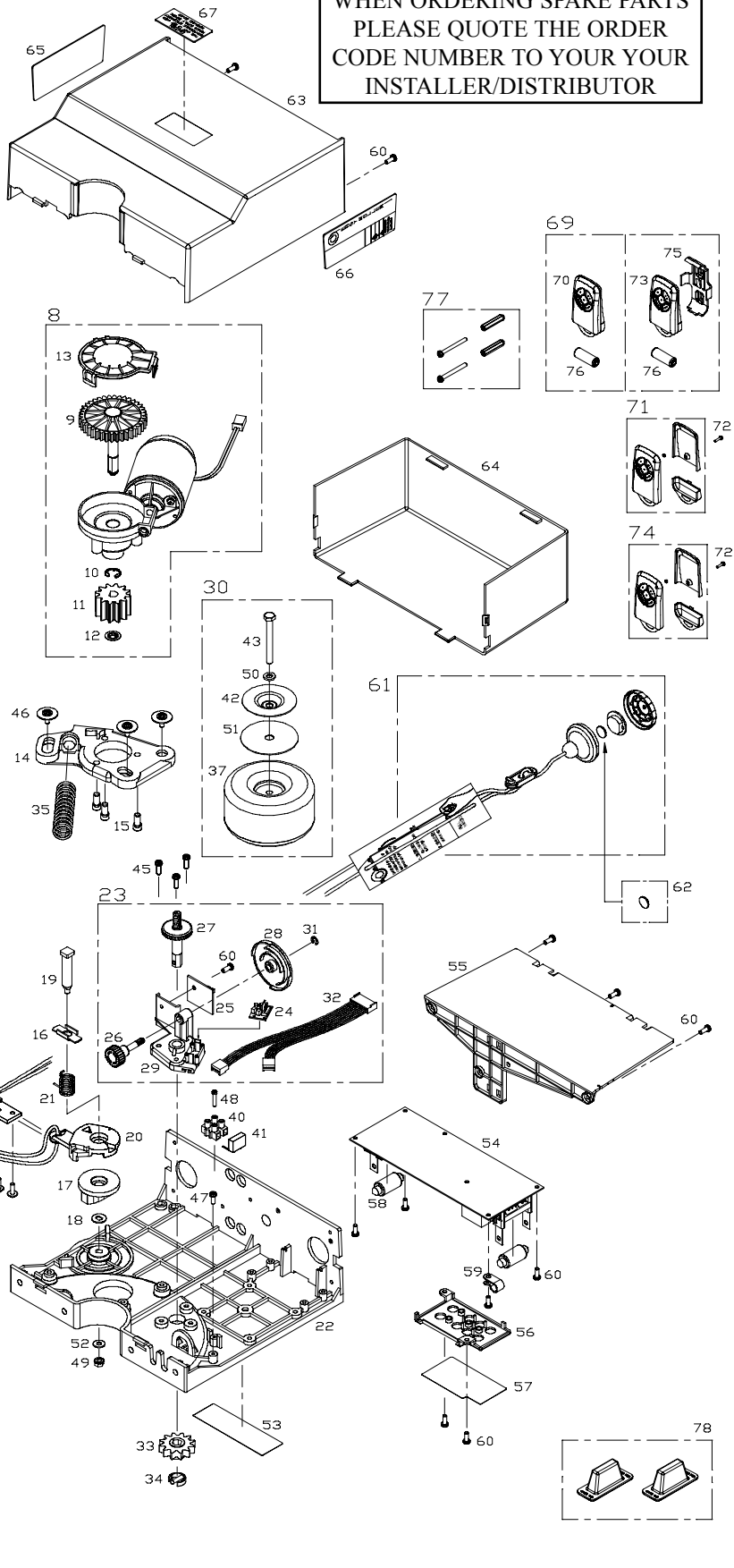

WARRANTY AND EXCLUSION OF LIABILITY

Subject to all of the matter set out below, Automatic Technology Australia Pty Ltd ("ATA") warrants the EasyRoller® Roll Up Door Opener ("The Product") for twenty four (24) months, from the date of purchase (specified in the sales docket receipt) that the product is free of any defects in material and workmanship rendering it unmerchantable.

This warranty referred to above applied only where:

- a) the consumer seeking to rely on the said warranty;
 - 1) returns the product which it claims to be defective; and
 - 2) presents the relevant sales docket and this warranty document to the retailer from whom the product was purchased to confirm that date of purchase; and
- b) the purchaser notified ATA or the retailer from whom the product was purchased of the alleged defect in the product immediately upon experience or learning of the alleged defect.

Except for the warranty against defects in material and workmanship set out above, ATA gives no warranties of any kind whatsoever, whether express or implied or whether statutory or at common law, in relation to the product, and all warranties of fitness for particular purpose and other warranties of whatsoever kind relating to the product are hereby declined. Without limiting the generality of the foregoing, ATA disclaims any liability of whatsoever nature in respect of any claim or demand loss or damage which arises out of;

- a) accidental damage to or normal wear and tear to the Product or to the Product's components;
- b) flood, rain, water, fire or lightning;
- c) incorrect, improper or unreasonable maintenance and/or use;
- d) installation, adjustment or use other than ATA which is not in accordance with the instructions set out in installation instructions incorporated in the document;
- e) attempted or complete modification or repairs to the Product carried out by a person who is not authorised by ATA to carry out such modification or repairs;
- f) faulty or unsuitable wiring of structure to which the Product is fixed or connected;
- g) radio (including citizen band transmission) or any electronic interference;
- h) blown fuses or damage caused by electrical surges;
- i) damage caused by insects.
- j) installation of a residential garage door or gate opener in a commercial or industrial situation

ATA's liability under the warranty set out above is limited, at ATA's absolute option, to replacing or repairing the product which ATA, in its unfettered opinion, considers to be defective either in material and/or workmanship or to credit the dealer with the price at which the product was purchased by the dealer. This warranty does not extend to cover labour for installation.

Where the Product is retailed by any person other than ATA, except for the warranty set out above, such person has no authority from ATA to give any warranty or guarantee on ATA's behalf in addition to the warranty set out above.

Purchased From _____	Phone _____
Installed By _____	Date _____
Serial No. _____	

AUTOMATIC TECHNOLOGY AUSTRALIA PTY LTD

ABN 11 007 125 368

17-19 Advantage Rd, Highett, Victoria, Australia 3190

Tel: +61 3 9532 2788 Fax: +61 3 9532 2799

Web: www.ata-aust.com.au Email: sales@ata-aust.com.au