





















TABLE OF CONTENTS

| | |
|--|----|
| Safety Warnings..... | 4 |
| Product Features..... | 5 |
| Operating Controls..... | 6 |
| Package Contents..... | 8 |
| Side Room Requirements..... | 9 |
| Fixing Weight Bars..... | 9 |
| Fitting Locking Bar Covers | 9 |
| Easy Access Transmitter..... | 10 |
| Mounting The Opener..... | 11 |
| Fixing Curtain To Drum..... | 12 |
| Setting Limits Via Control Panel..... | 12 |
| Setting Limits Via Transmitter..... | 13 |
| Setting Obstruction Force Margin (ISS)..... | 14 |
| Re-Calculating Force Margin Sensitivity..... | 14 |
| Coding Transmitters | 15 |
| Deleting Transmitters | 16 |
| Connecting Photo Electric Beam..... | 17 |
| Setting Auto-Close Time..... | 17 |
| Using Manual Release..... | 17 |
| Setting Courtesy Light Time..... | 18 |
| Setting Pet Mode Door Opening Position..... | 18 |
| Resetting Factory Defaults..... | 18 |
| Door Status Indicators..... | 19 |
| Buttons and Functions..... | 19 |
| Factory Default Settings..... | 20 |
| Technical Specifications..... | 20 |
| Trouble Shooting Guide..... | 21 |
| Parts List..... | 22 |
| Warranty..... | 23 |

IMPORTANT SAFETY INSTRUCTIONS

Warning - It is vital for the safety of persons to follow all instructions. Failure to comply with the following Safety Rules may result in serious personal injury and/or property damage.

-  For **ADDITIONAL SAFETY** protection we **STRONGLY** recommend the fitting of a Photo Electric Beam. In most countries Photo Electric Beams are mandatory on all garage doors fitted with automatic openers. For a small additional outlay ATA recommends that Photo Electric Beams be installed with the automatic opener ensuring additional safety and peace of mind.
-  **DO NOT** operate the garage door opener unless the garage door is in full view and free from objects such as cars and children/people. Make sure that the door has finished moving before entering or leaving the garage.
-  **DO NOT** operate the garage door opener when children/persons are near the door. Children must be supervised near the garage door at all times when the door opener is in use. **SERIOUS PERSONAL INJURY** and/or property damage can result from failure to follow this warning.
-  **DO NOT** allow children to operate the garage door opener. **SERIOUS PERSONAL INJURY** and/or property damage can result from failure to follow this warning.
-  Regularly check to make sure that the **SAFETY OBSTRUCTION FORCE** is working correctly, and is **TESTED** (by placing a 50mm high object on the floor) and set as per the Installation Instructions Manual. Failure to follow the manual could result in **SERIOUS PERSONAL INJURY** and/or property damage. This test must be repeated at regular intervals and the necessary adjustments made as required.
-  **DO NOT** disengage the door opener to manual operation with children/persons or any other objects including motor vehicles within the doorway.
-  Install the wall switch or wall mounted transmitter in a location where it is out of reach of children and the garage door is visible.
-  The door opener is not intended for use by young children or infirm persons without adequate supervision. Children should be supervised to ensure that they do not play with the remote transmitters or the opener.
-  Keep hands and loose clothing **CLEAR** of the door and door opener at all times.
-  The unit should be installed so that it is protected from the elements. It should not be exposed to water or rain. It is not to be immersed in water or sprayed directly by a hose or other water carrying device.
-  The garage door must be **WELL BALANCED**. Sticking or binding doors must be repaired by a qualified garage door installer prior to installation of the opener.
-  Frequently examine the installation, in particular cables, springs and mountings for signs of wear, damage or imbalance. **DO NOT** use if repair or adjustment is needed since a fault in the installation or an incorrectly balanced door may cause injury. **DO NOT** attempt to repair the door yourself as hardware is under extreme tension.
-  **REMOVE OR DISENGAGE** all garage door locks and mechanisms prior to installation of the opener.
-  Connect the garage door opener to a properly **EARTHED** general purpose 240V mains power outlet installed by a qualified electrical contractor.
-  **DISCONNECT THE POWER CORD** from mains power before making any repairs or removing covers. Only **EXPERIENCED** service personnel should remove covers from the garage door opener.
-  When using auto close mode, a **PHOTO ELECTRIC BEAM** must be fitted correctly and tested for operation at regular intervals. **EXTREME CAUTION** is recommended when using auto close mode. **ALL SAFETY RULES** must be followed.
-  In order for the garage door opener to **SENSE** an object obstructing the door way, some **FORCE** must be exerted on the object. As a result the object, door and/or person may suffer **DAMAGE or INJURY**.
-  If the power supply cord is damaged, it **MUST** be replaced by an ATA service agent or suitably qualified person.
-  Make sure that the door is fully open before driving in or out of the garage and fully closed before leaving the driveway.
-  Make sure that remote controls are kept out of reach of children.

Automatic Technology Australia Pty Ltd to the extent that such may be lawfully excluded hereby expressly disclaims all conditions or warranties, statutory or otherwise which may be implied by laws as conditions or warranties of purchase of an Automatic Technology Australia Pty Ltd Roll Up Garage Door Opener. Automatic Technology Australia Pty Ltd hereby further expressly excludes all or any liability for any injury, damage, cost, expense or claim whatsoever suffered by any person as a result whether directly or indirectly from failure to install the Automatic Technology Australia Roll Up Garage Door Opener in accordance with these installation instructions.

FEATURES

Thank you for purchasing the ATA EasyRoller Automatic Garage Door Opener. This opener is designed to suit vertical operating continuous curtain roll up doors. The components and materials used in this opener are of the latest technology and highest quality. Listed below are some of the many features.

OPERATION

To open or close the door simply press the hand held transmitter, the wall mounted transmitter, or optional wall switch for two seconds. During an open or close cycle the door can be stopped by pressing the button while the door is in motion. The next actuation will move the door in the opposite direction.

HOPPING CODE

Every time a transmission is made from the *remote* transmitter a new security code is generated. The number of possible code combinations is over 4.29 billion. This greatly enhances the security of the system. Code "grabbing" is made a thing of the past.

ALPS (AUTOMATIC LIMITS POSITIONING SYSTEM)

A revolutionary door travel limits positioning system., the new ALPS technology does away with manual adjustment of the doors' limits position using mechanical parts, such as cams and micro switches.

The ALPS technology automatically calculates the doors' travel limits and stores it in memory. If the door is moved manually within the travel limits during a power failure, the ALPS will recognise this once the power is restored and stop at the correct limit position if the door is activated.

During installation the hand held transmitter can be programmed to set the door limits positions.

ISS (INTELLIGENT SAFETY OBSTRUCTION SYSTEM)

While the door is performing a close cycle, should it hit an obstacle or be restricted in some manner, it will automatically reverse. The amount of force the door should encounter before reversing is automatically adjusted by the doors control system during the initialisation of the automatic door opener. The door will also stop if restricted whilst opening. The Safety Obstruction Force should be checked at least once a month. See installation manual for instructions.

SECURITY CODE STORE

The EasyRoller Garage Door Opener uses state of the art technology in storing your selected transmitter security code. Up to 23 different transmitters can be stored in the openers memory.

OVER LOAD INDICATOR

When the maximum opening and closing capacity of the opener is exceeded an audible beeper will sound to indicate that an overload has occurred.

AUTO COURTESY LIGHT

The courtesy light on the opener comes on automatically whenever the door is activated. The light can also be switched on and off without operating the door. This is done by pressing the button on any hand held or wall mounted transmitter which has been stored with the light code. The light will stay on for approximately three minutes then switch off. This time is also adjustable.

BATTERY BACK UP (OPTIONAL)

The opener has provision to include a battery back module. This is an ideal addition if the garage door is the only entrance to the garage or if the area is prone to power cuts.

VACATION MODE

A hand held transmitter can be programmed to lock and unlock all other transmitters that have being programmed into the openers' memory. The vacation mode can be used when the door is left idle for long periods of time.

PET (PEDESTRIAN) MODE

The hand held transmitter can be programmed to open the door partially so that the family pet can enter and exit the garage at any time. You may also wish to open the door to a height suitable only for pedestrian access. The pet door opening height is adjustable.

AUTO CLOSE MODE

The opener can be programmed to automatically close after an open cycle. The auto close time is adjustable. It is compulsory to install a Photo Electric Beam if this mode is selected, otherwise the door may cause personal injury or damage to property.

PHOTO ELECTRIC BEAM (OPTIONAL)

The opener has an input for a photo electric beam to be connected for extra safety protection and use of the auto close mode.

MANUAL OPERATION

The opener is equipped with a unique patented manual disengaging device. If the power to the opener is disrupted for any reason the door can be put into manual mode by pulling down on the string handle, then releasing. This will allow you to manually open or close the door. When power is restored, by pulling down on the string handle and releasing, the opener is put back into automatic mode.

OPERATING CONTROLS

1. **24V OUTPUT** supplies 24V DC at 30mA to power an external receiver, or electronic device, etc.

P. E. SHUNT. The shunt has to be removed when connecting a Photo Electric Beam.

NOTE: P.E. SHUNT must not be removed otherwise the opener will not function correctly. Remove only when a P.E beam is to be connected.

O/S/C INPUT is used for the connection of a wired switch (momentary contact). This switch can then be used to open, stop or close the door. Install the wall switch in a location where the switch is out of reach of children and the garage door is visible.

LIGHT INPUT is used to control external courtesy lights either independently via remote control or when the door is activated.

2. **LIGHT CODE button** (white) is used for storing or erasing the transmitter button (code) you wish to use to switch the opener's courtesy light on and off.
3. **CODING LED** (red) light indicates whether a code is being stored or when a transmitter button is pressed.
4. **DOOR CODE button** (blue) is used for storing or erasing the transmitter button you wish to use to command the door to open, stop or close.
5. **STATUS LED** (Yellow) indicates if opener is overloaded or requires service.

6. **CLOSE drive button** (red) is used during installation to help set the close limit position. Pressing and holding this button will move the door in the close direction. Movement stops when the button is released.

NOTE: The close safety obstruction detection is inoperable whenever the Close Drive button is used to move door. This button is disabled after initialisation.

7. **CLOSE LIMIT LED** (red) the led is very helpful during installation. It illuminates and flashes when the door is closing and remains steady on when the close limit position has been reached.
8. **AUTO CLOSE TIME button** (White) is used to adjust the auto close time. While holding in the auto close button and then pressing the open button the time is increased. Each press will increase the time by 5 seconds. Pressing the close button will decrease the time.
9. **ENGAGE/DISENGAGEMENT CORD** is used to switch the door into manual mode especially in case of a power failure. The length of the string is also adjustable.

EASY ACCESS

TRANSMITTER The "manual release" engage/disengagement handle has a wireless transmitter within its housing. If the button is pressed it will open, stop or close the garage door.

10. **SET button** (yellow) is used during the installation phase together with the Open and Close buttons to set the door limit positions. The Set button is also used to re-initialise the Opener.

11. **O/S/C button** (Yellow) is used during installation to test the open, stop and close cycles for the opener. The opener has to be initialised by the Set button before the O/S/C button becomes operable.

12. **BATTERY CHARGER INPUT** is used for the connection of a battery charger.

13. **OPEN DRIVE button** (green) is used during installation to help set the open limit position. Pressing and holding this button will move the door in the open direction. Movement stops when the button is released.

NOTE: The open safety obstruction detection is inoperable whenever the Close Drive button is used to move door. This button is disabled after initialisation.

14. **OPEN LIMIT LED** (green) the led is very helpful during installation. It illuminates and flashes when the door is opening and remains steady on when the open limit position has been reached.

15. **FORCE MARGIN SET** The obstruction force pressure is set automatically by the opener during installation. The pressure can be adjusted manually using the Force Margin Set button (White). Pressing the force margin set button and open or close button will increase or decrease the amount of force. The Force Margin Set is only ever used if other environmental factors (wind, etc.) affect the operations of the door/opener.

16. **PROG INPUT** is used for the connection of the ATA Universal Programmer for the purpose of editing control and receiver functions.

OPERATING CONTROLS

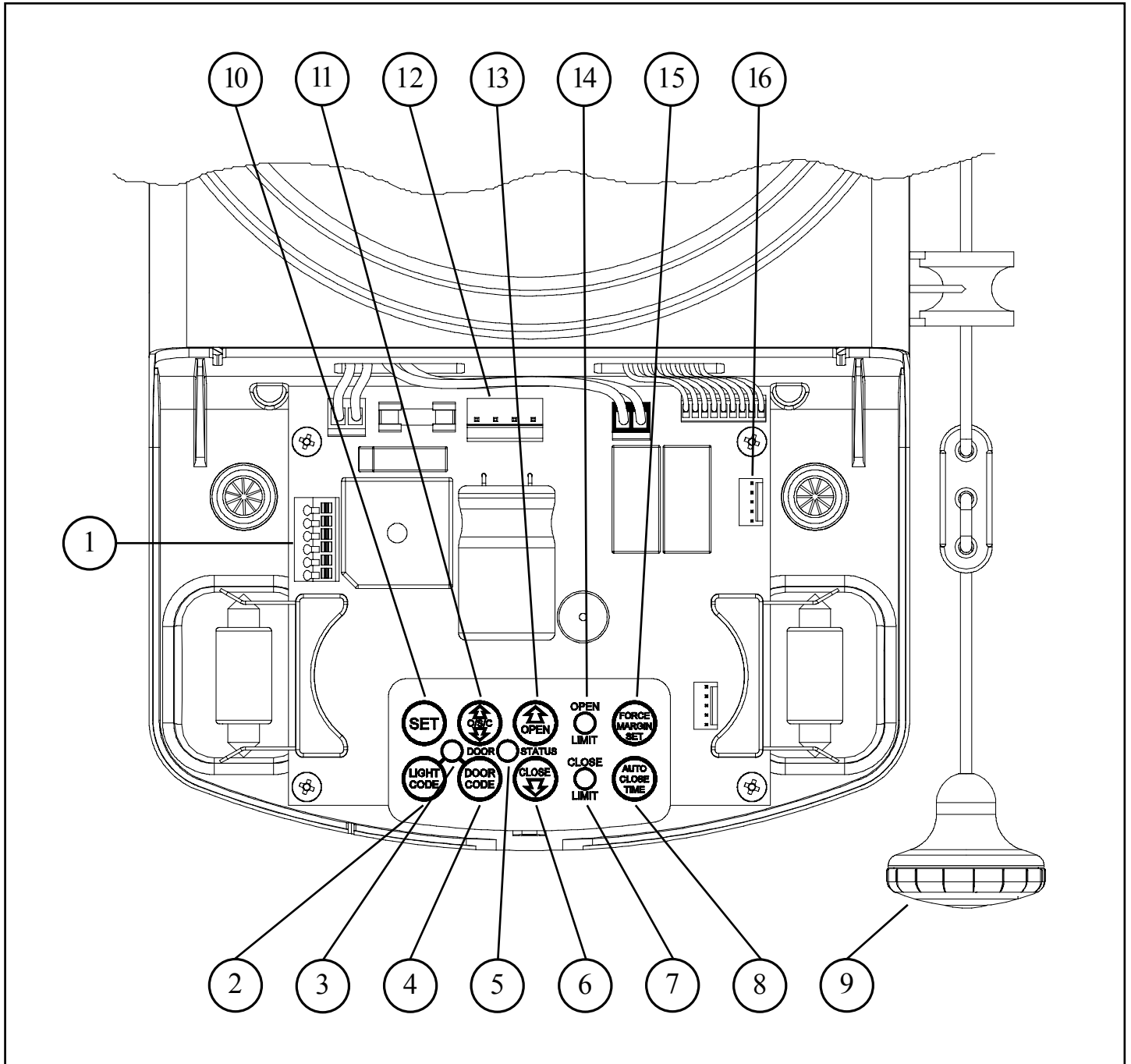

- | | |
|---|--|
| <p>1) P.E. SHUNT, OSC INPUT, LIGHT INPUT 24V DC OUTPUT</p> <p>2) LIGHT CODE BUTTON (WHITE)</p> <p>3) CODING LED (RED)</p> <p>4) DOOR CODE BUTTON (BLUE)</p> <p>5) DOOR STATUS LED (YELLOW)</p> <p>6) CLOSE DRIVE BUTTON (RED)</p> <p>7) CLOSE LIMIT LED (RED)</p> <p>8) AUTO CLOSE BUTTON (WHITE)</p> | <p>9) ENGAGE/DISENGAGEMENT HANDLE INC. EASY ACCESS TRANSMITTER</p> <p>10) SET BUTTON (YELLOW)</p> <p>11) O/S/C BUTTON (YELLOW)</p> <p>12) BATTERY CHARGER INPUT</p> <p>13) OPEN DRIVE BUTTON (GREEN)</p> <p>14) OPEN LIMIT LED(GREEN)</p> <p>15) FORCE MARGIN SET BUTTON</p> <p>16) PROGRAMMER INPUT</p> |
|---|--|

PACKAGE CONTENTS

| ITEM | QUANTITY |
|---|----------|
| GDO-6 SLIM-DRIVE EASYROLLER® DRIVE UNIT | 1 |
| EASY ACCESS TRANSMITTER EAT-1 (NOT INCLUDED IN SOME MODELS) | 1 |
| KEY RING TRANSMITTER PTX-4 | 2 |
| PTX-4 WALL MOUNT BRACKET | 1 |
| ALKALINE BATTERY A23 12V | 2 |
| WEIGHT BAR (NOT INCLUDED IN SOME MODELS) | 1 |
| PAN HEAD SCREW M4x50mm (NOT INCLUDED IN SOME MODELS) | 2 |
| NILOCK HEX NUT M4 (NOT INCLUDED IN SOME MODELS) | 2 |
| FLAT WASHER I.D 3/16 x 1/2 (NOT INCLUDED IN SOME MODELS) | 2 |
| SCREW #6x1" | 2 |
| PLASTIC WALL PLUGS | 2 |
| LOCKING BAR COVERS | 2 |
| INSTALLATION MANUAL | 1 |

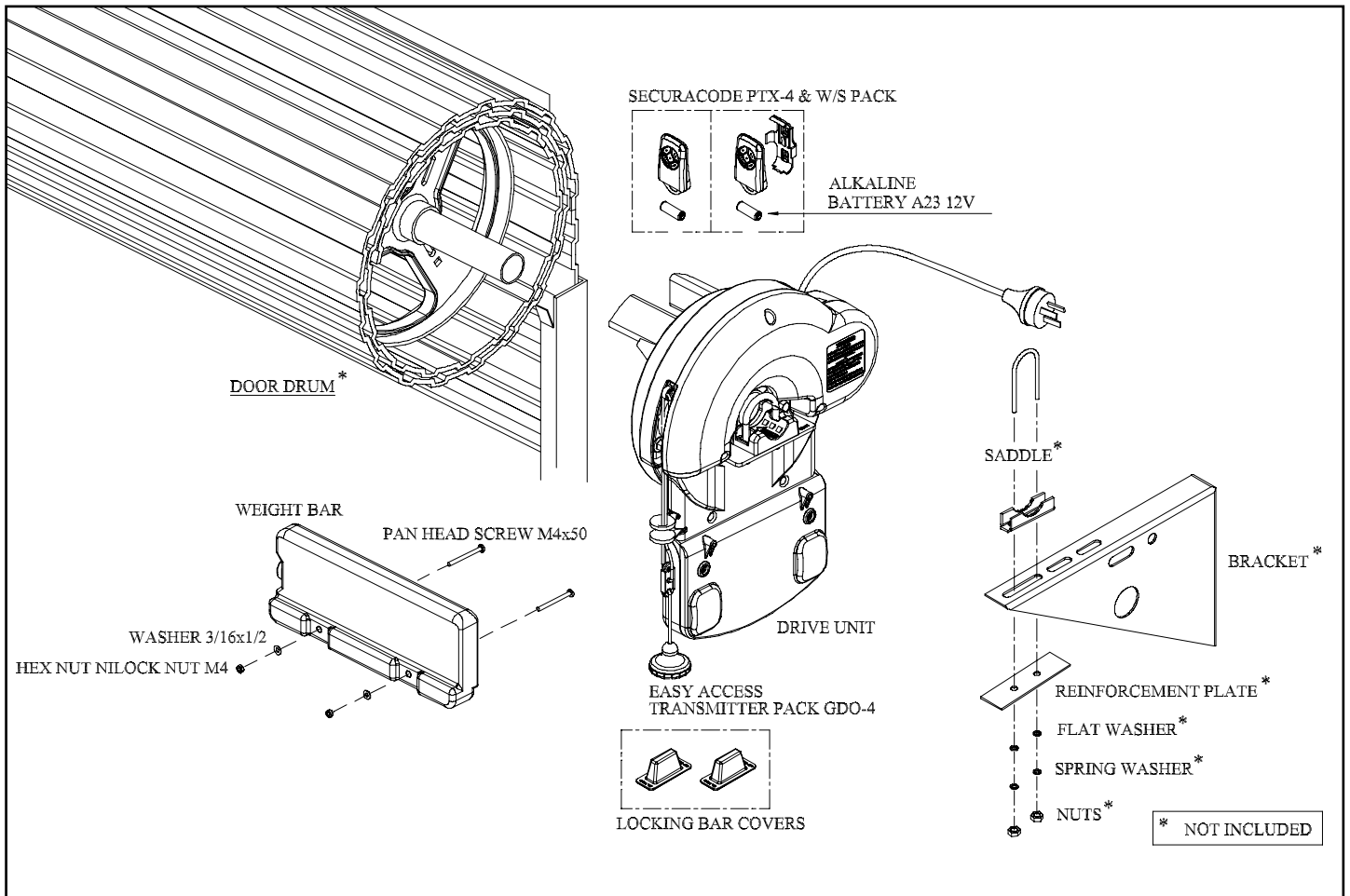

BEFORE INSTALLATION

IMPORTANT SAFETY INSTRUCTIONS FOR INSTALLATION

Warning: Incorrect installation can lead to severe injury. Follow ALL installation instructions.

SIDE ROOM REQUIREMENTS

Fig. 1 shows the minimum and recommended side room that is required to mount the opener. The distance between the edge of the door curtain and the inside of the bracket must be at least 40mm. However, for easier access it is recommended that at least 95mm is allowed.

1. CHECK OPERATION OF DOOR

BEFORE BEGINNING THE INSTALLATION OF THE EASYROLLER AUTOMATIC OPENER CHECK THE OPERATION OF THE DOOR.

The door must be well balanced and be in a reasonable operating condition. You should be able to lift the door smoothly and with little resistance. It should stay open around 900mm to 1200mm above the floor. The door should not stick or bind in the guide tracks. The ideal operational effort in raising or lowering the door should not exceed a force of 10kg (22 lbs.). Make sure that all door locks, ropes, chains etc. are either released, or disabled and remove unnecessary accessories.

2. FIXING OF DOOR WEIGHT BAR

Move the door manually to the mid open position. Place the weight bar on the bottom rail, in the middle of the door and secure with the fasteners provided (Fig. 2). Check the operation of the door again. If the door feels heavy it may require extra tension to be added to the door springs. Refer to the door Installation manual from the manufacturer on how to tension the door.

3. INSTALLING LOCKING BAR COVERS

To protect against entrapment of fingers etc. inserted into door guides – remove the protective backing of the double sided tape and install the locking bar covers over the holes in each door guide.

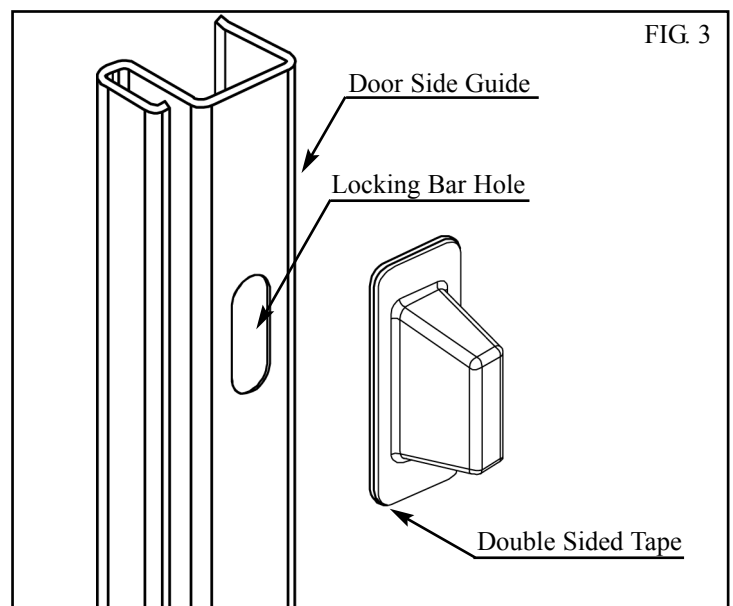
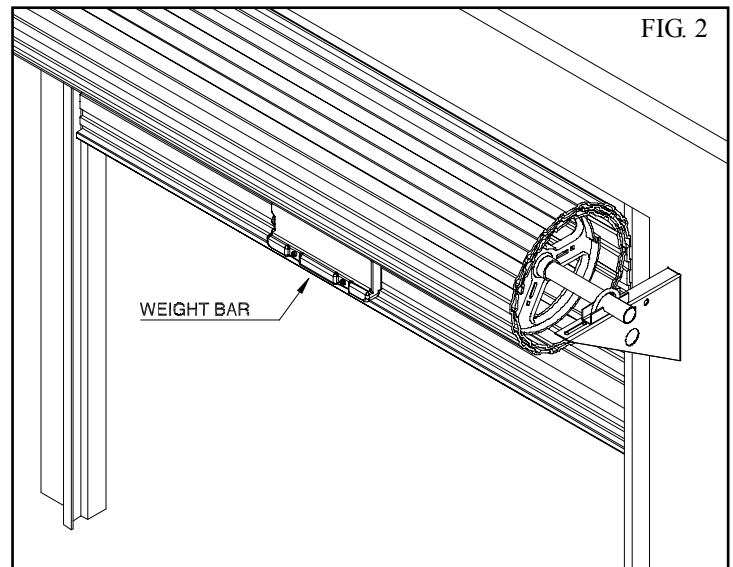
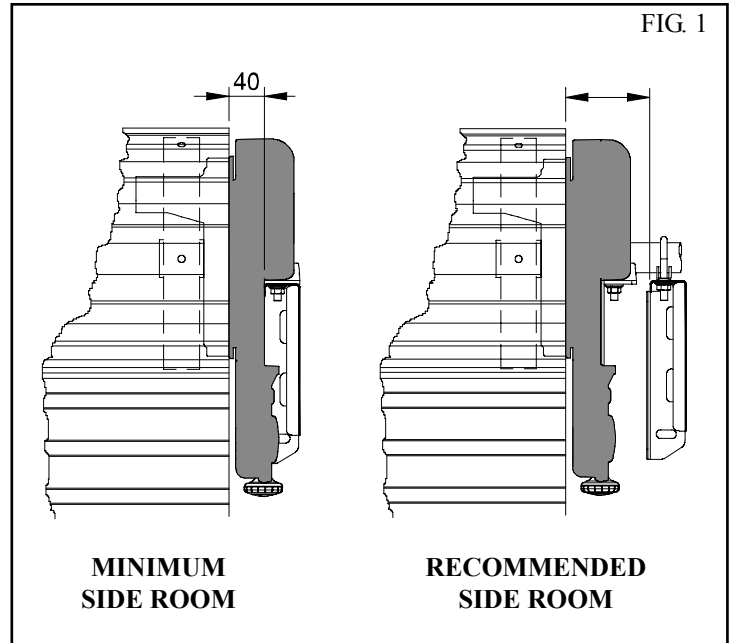

EASY ACCESS TRANSMITTER

4. EASY ACCESS TRANSMITTER

The Easy Access Transmitter is prepared ready for use with the battery pre-installed. Before the transmitter can be operational, the Transmitter Code has to be stored into the openers memory. To store the code please follow the instructions in Step 10.1 on page 15.

REMOVING THE COVER TO REPLACE BATTERY

1. Rotate the cover Clockwise to CLOSE
2. Rotate the cover Anti-clockwise to OPEN

REMOVING THE BATTERY

(Battery Type: 3V Lithium Battery CR1220).

Use a non-metallic object (e.g Pen) to remove the battery. Gently lever the battery out of the holder, taking care to not damage the circuit board. (Fig. 6)

WARNING

Metallic objects used to remove the battery may DAMAGE the the circuit board or the battery.

REPLACING THE BATTERY

Make sure that positive (+) side is facing up. Place one side of the battery into the holder (Fig. 7), then press the battery in and down firmly until it clicks into a flat position.

Note: The length of the manual release cord is user adjustable simply by sliding the plastic toggle along the cord to achieve the desired length.

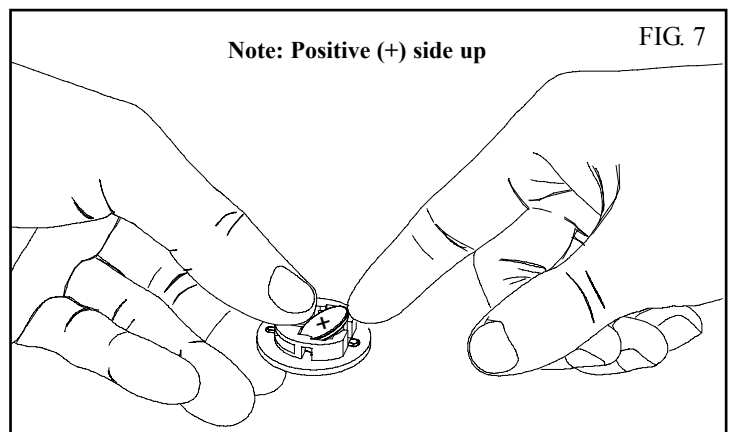
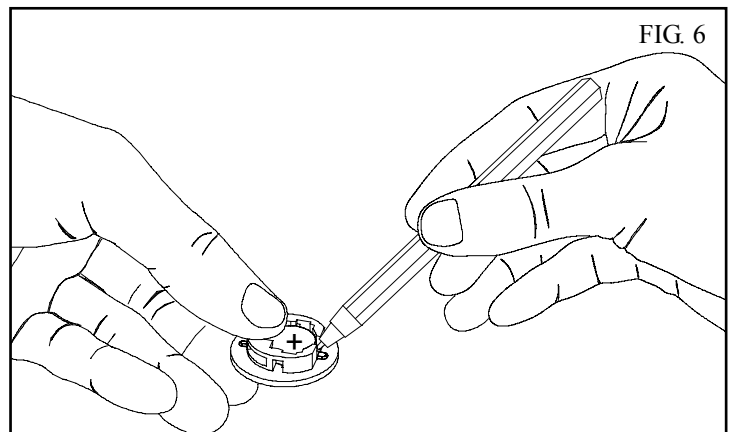
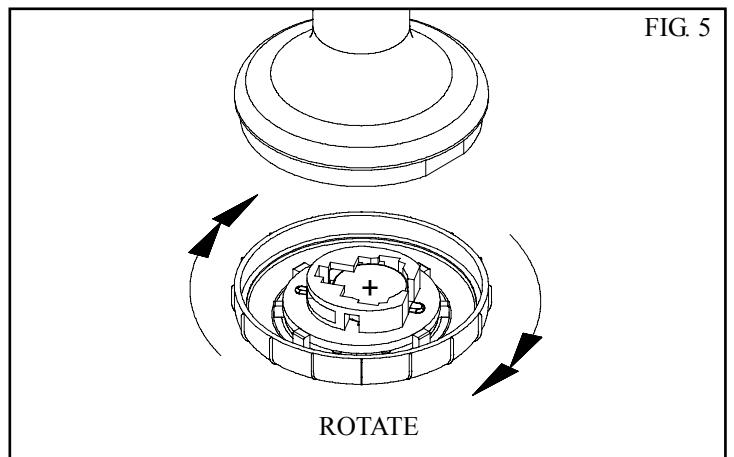
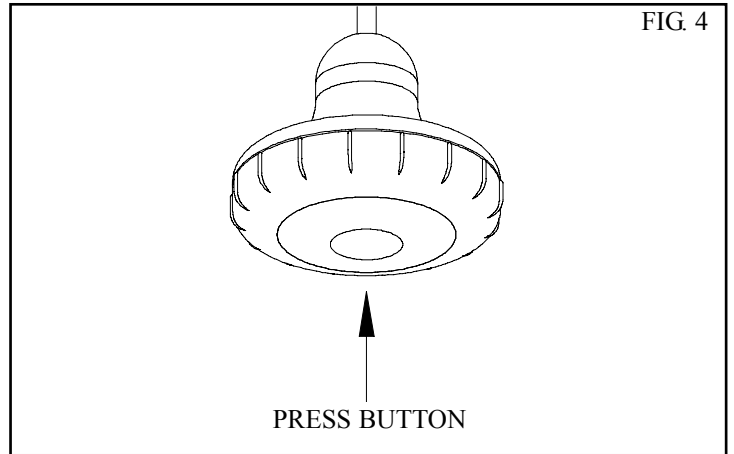

MOUNTING THE OPENER

5. FIXING DRIVE UNIT TO THE DOOR

The EasyRoller Drive Assembly can be fixed to the roll up garage door in a variety of ways. Described below is one method of fixing. Make sure there is enough side room to slide the drive assembly onto shaft.

PLEASE NOTE: THE INSTRUCTIONS FOR FIXING THE DRIVE ASSEMBLY TO THE DOOR IS FOR RIGHT HAND INSTALLATION.

FITTING DRIVE UNIT TO DOOR

(Fig. 8, Fig. 9, and Fig. 10).

1. Check that the door shaft U bolt is securely tightened on the left hand side of the door.
2. Raise the door and tie a rope around the centre to secure the roll.
3. Support the right hand end of the door with a suitable prop, e.g. step ladder and soft padding to protect door surface.

WARNING: DO NOT ALLOW CHILDREN/PERSONS AROUND THE DOOR AND PROP. SERIOUS PERSONAL INJURY AND/OR PROPERTY DAMAGE CAN RESULT FROM FAILURE TO FOLLOW THIS WARNING.

4. Check that Step 3. was completed. Carefully loosen and remove the right hand door shaft U bolt.
5. Make sure that the door supporting prop is secure. While the door is supported remove the right hand door mounting bracket from wall.
6. Remove the drive assembly from the packaging. Try to rotate the drive gear by pushing on the fork. If the gear does not rotate the manual mode has to be selected. To select pull downward on the string handle, then release slowly. The drive gear should now rotate freely.
7. Slide the drive assembly over the door axle making sure that the fork extends into and over one of the spokes of the door drum wheel.
8. Refit the door mounting bracket to the wall. In some cases the bracket may have to be re-positioned. Re-fit and tighten the door shaft U bolt. Remove door supporting prop and untie the rope from the curtain.
9. Straighten the drive assembly and position as per Fig. 10. Tighten the two locking bolts firmly to secure the Drive Unit.
10. Check the manual operation of the door by raising and lowering the door. The door should run smoothly and not catch on any part of the drive assembly.
11. Adjust the length of the manual release cord so that it can be easily reached by an adult of average height (ie. less than 1.8m tall).

NOTE: After installation, ensure that parts do not extend over public footpaths or roads.

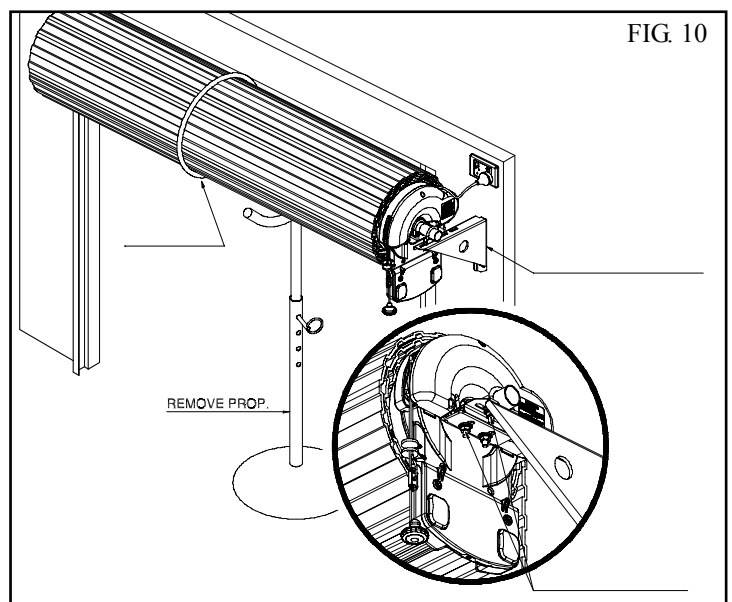
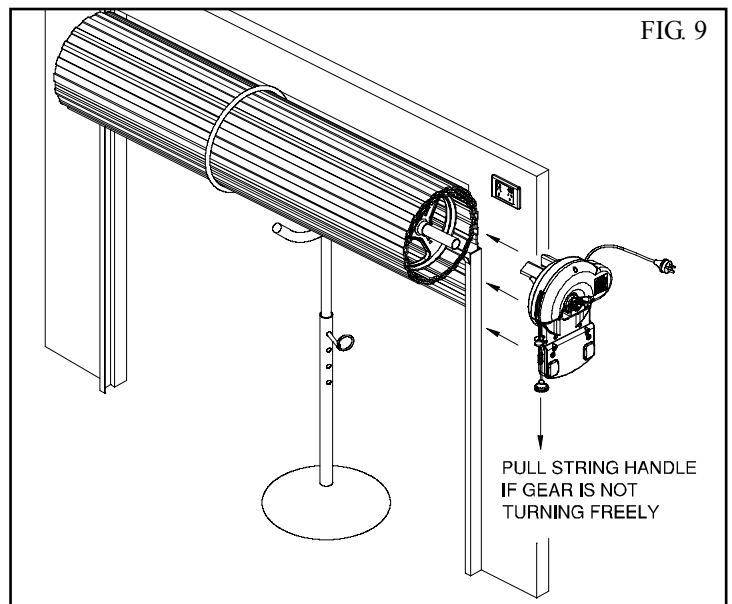
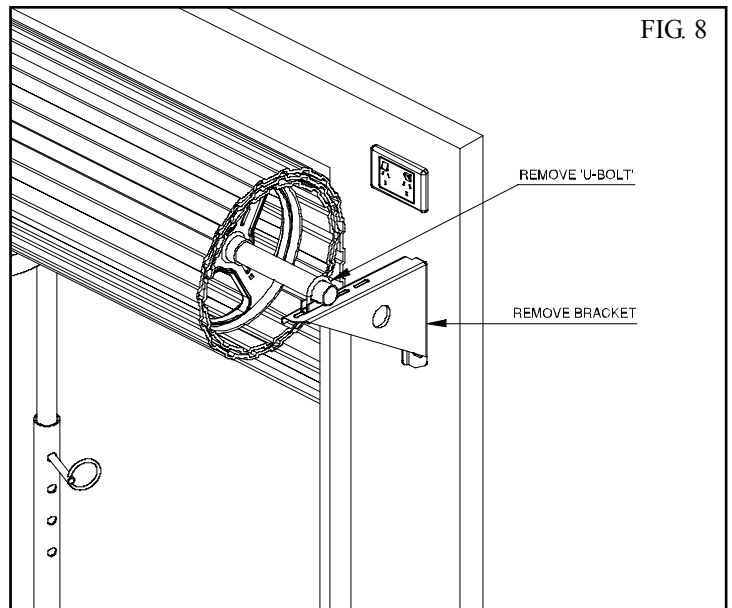

SETTING LIMITS

6. FIXING OF DOOR CURTAIN TO DRUM WHEEL

The door curtain has to be secured to the drum wheel with suitable fasteners.

1. With the door in the fully closed position, mark the curtain (Fig. 11) on both ends of the door.
2. Open door slightly to have access to the marked positions. Secure the curtain to drum wheel using self drilling screws (two on each end). The screws should be at least 90 degrees apart.

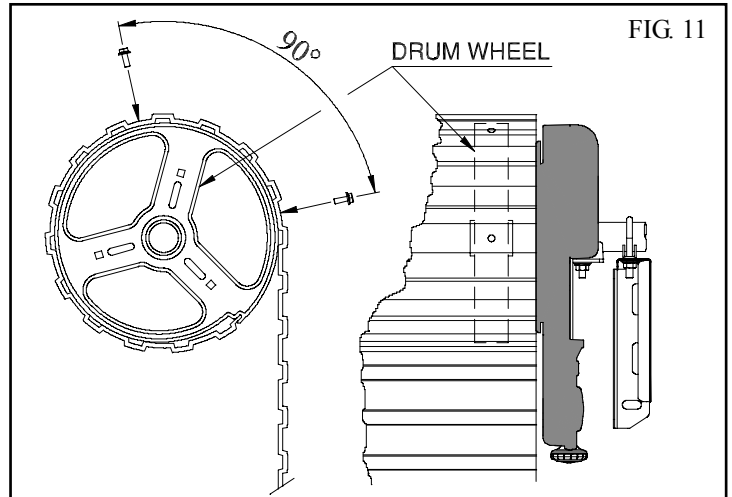

7. SETTING DOOR TRAVEL LIMITS POSITIONS - METHOD ONE - VIA THE CONTROL PANEL

IMPORTANT NOTE: The O/S/C button will not function until the open and close limits positions are set.

NOTE: The opener is factory preset for installation on the **RIGHT HAND SIDE**. When the opener is mounted on the left side of the door the opener will travel in reverse. To change the direction of travel for **LEFT HAND SIDE** installation do the following step - otherwise proceed with step 7.1:

1. Make sure the opener is engaged and power is connected.
2. Press the Close button briefly. The door should start to close.
3. If the door opens - release and press the OSC button within 2 seconds.
4. Press the Close button again to confirm that the door is moving in the correct direction.

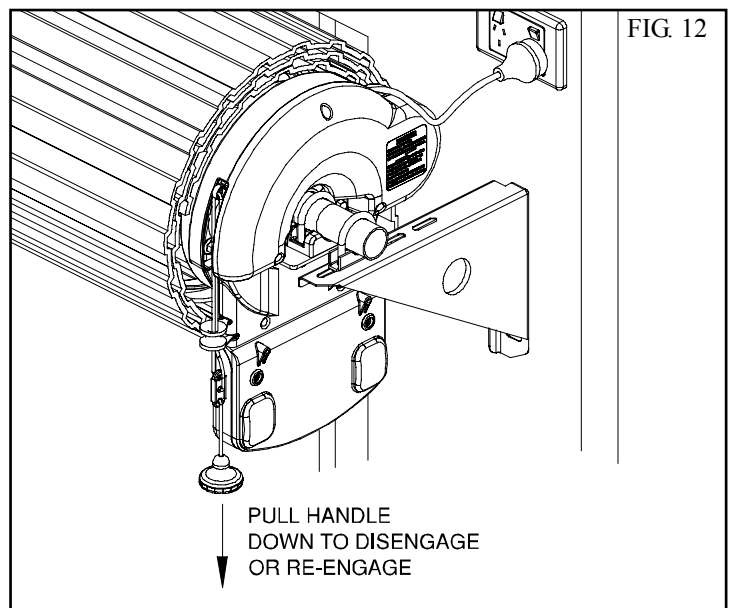

7.1 SETTING LIMITS POSITIONS

1. With the drive assembly in manual mode (Fig. 12) move the door up by hand to an approximately mid open position.
2. Re-engage the drive gear to the door by pulling down on the string and then releasing.
3. Plug in the opener and turn the power on.
4. Press the Close button (Fig. 13), the door will start closing. Release the button once you have reached your desired closed limit position.
5. Press the Set button. This action will store the closed limit position into memory.
6. Press the Open button, the door will start opening. Release the button once you have reached your desired open limit position.

IMPORTANT WARNING: Please be aware that the garage door will start closing automatically once step 7 is performed. The door will also automatically re-open after fully closing with a short pause between the cycles.

7. Press the Set button (Fig. 13). This action will store into memory the open limit position. The door will now automatically close to its limit position then fully open to calculate the safety obstruction forces (ISS). Please be aware of the above warning. The opener can now be operated from the O/S/C Button.

Go to STEP 9 and test the Safety Obstruction Force.

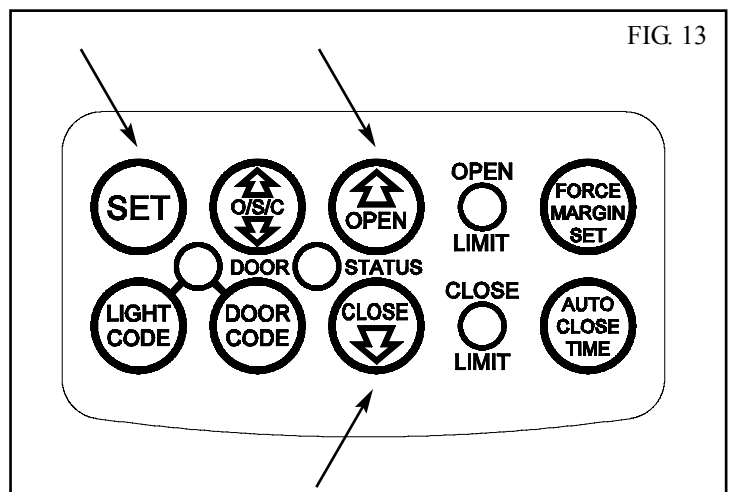

7.2 RESETTING DOOR LIMIT POSITIONS

The door travel limit positions can be deleted for new positions by following the steps below:

1. Press and hold the Close button (Fig. 13) for six (6) seconds until you hear three beeps and the red Close Limit LED starts to flash. Release the button.
2. Follow STEP 7.1 1 to 7 to set new travel limit positions.

SETTING LIMITS

8. SETTING DOOR TRAVEL LIMIT POSITIONS – METHOD TWO - VIA THE REMOTE CONTROL

IMPORTANT NOTE: The O/S/C button will not function until the open and close limits position are set.

NOTE: The opener is factory preset for installation on the **RIGHT HAND SIDE**. When the opener is mounted on the left side of the door the opener will travel in reverse. To change the direction of travel for **LEFT HAND SIDE** installation do the following:

1. Make sure the opener is engaged and power is connected.
2. Press the Close button briefly. The door should start to close.
3. If the door opens - release and press the OSC button within 2 seconds.
4. Press the Close button again to confirm that the door is moving in the correct direction.

8.1 SETTING LIMITS

1. With the drive assembly in manual mode (**Fig. 12**) move the door up by hand to an approximately mid open position.
2. Re-engage the drive gear to the door by pulling down on the string and then releasing.
3. Plug in the opener and turn the power on.
4. Press and hold the Door Code button (**Fig. 14**).
5. Press button 1 (**Fig. 15**) on the transmitter for two seconds. Release and pause for two seconds. Press the same button again on the transmitter for two seconds.
6. Release the Door Code button.
7. With the drive assembly in manual mode move the door up by hand to an approximately mid open position.
8. Re-engage the drive gear to door by pulling down on the string and then releasing.
9. Press button 4, the door will start closing, release the button once you are 1 to 2 cm from your desired closed limit position. Press button 3 for two seconds then release.
10. Press button 4, each press will enable you to inch the door to your desired closed position.
11. Once you are happy with the position press button 2, this action will store into memory the closed limit position.
12. Press button 1, the door will start opening. Release the button once you are 1 to 2 cm from your desired open limit position. Press button 3 for two seconds then release.
13. Press button 1. Each press will enable you to inch the door to your desired closed position.

IMPORTANT WARNING: Please be aware that the garage door will start closing automatically once step 14 is performed. The door will also automatically re-open after fully closing with a short pause between the cycles.

14. Once you are happy with the position press button 2, this action will store into memory the open limit position. The door will now automatically close to its limit position then fully open to calculate the safety obstruction forces (ISS). Please be aware of the above warning.

Go to STEP 9 and test the Safety Obstruction Force.

FIG. 14

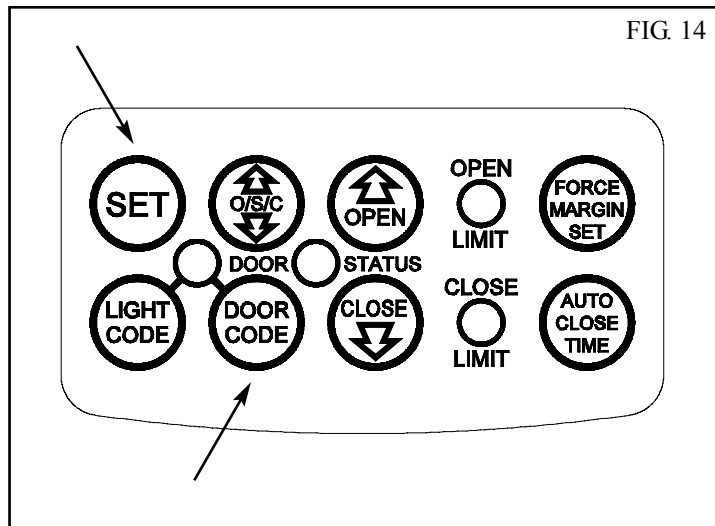
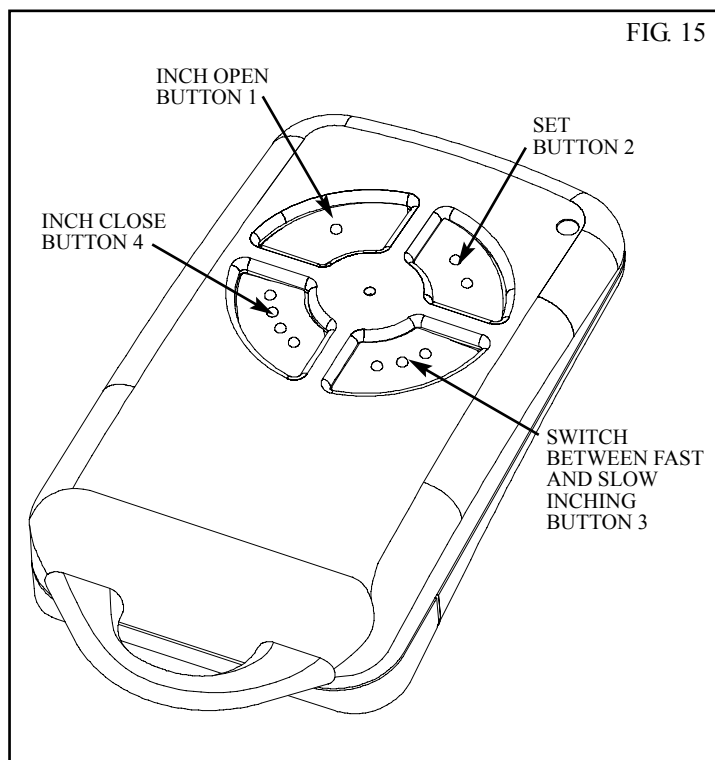

FIG. 15



8.2 RESETTING DOOR LIMITS POSITIONS

The door travel limit positions can be deleted for new positions by following the steps below:

1. Press and hold the Close button (**Fig. 16**) for six (6) seconds until you hear three beeps and the red Close Limit LED starts to flash. Release the button.

2. Follow STEP 8.1 1 to 14 to set new travel limit positions.

Important: There is no need to re-code the transmitter used for setting the limit positions. After the limits are set the transmitter will automatically reset to normal operation.

SETTING SAFETY OBSTRUCTION FORCE

9. SAFETY OBSTRUCTION TEST

Please take care when testing the Safety Obstruction Force. Due to Excessive forces failure to follow this warning may cause **SERIOUS PERSONAL INJURY** and/or property damage. The test below should be repeated at regular intervals (approximately every two months).

9.1 TESTING CLOSE CYCLE

1. Open the door by pressing the Yellow O/S/C button (Fig. 16).
2. Place a length of timber approximately 50mm high on the floor directly under the door (Fig. 17).
3. Press the Yellow O/S/C button to close door. The door should strike the object and start to re-open.
4. Press again to close the door. When the door is approximately one metre above the floor, hold the bottom rail of the door firmly, the door should re-open. If the door stops on the obstacle and fails to reopen, readjust and set the close limit lower (see Step 7.1). Re-test after you have adjusted the close limit.

IMPORTANT WARNING: If the test fails, there may be a problem with the door, discontinue use, put the door into manual operation and call for service.

9.2 TESTING OPEN CYCLE

1. Close the door by pressing the Yellow O/S/C button.
2. Press again to close the door. When the door is approximately one metre above the floor, hold the bottom rail of the door firmly, the door should stop.

ADJUSTING SAFETY OBSTRUCTION FORCE

The Safety Obstruction Force is calculated automatically and set in memory on the EasyRoller. It is usually not necessary to adjust the Safety Obstruction Force. The only time the force may need to be increased is due to environmental conditions, for example, windy or dusty areas, and areas with extreme temperature changes.

9.3 TO INCREASE FORCE PRESSURE

1. Press and hold the Force Margin Set button (Fig. 16)
2. While holding down the Force Margin button, press the Open button. Each press increases the force margin in both directions. The Open Limit LED will illuminate each time the Open button is pressed. Each press increases the force margin. Test the force as per step 9.1 and 9.2. If the Open Limit LED flashes continuously when the open button is being pressed, this indicates that the maximum force pressure setting has been reached.

9.4 TO DECREASE FORCE PRESSURE

1. Press and hold the Force Margin Set button (Fig. 16).
2. While holding down the Force Margin button, press the Close button. Each press decreases the forcemargin. The Close Limit LED will illuminate each time the close button is pressed. Test the force as per step 9.1 and 9.2. If the Close Limit LED flashes continuously when the Open button is being pressed, this indicates that the maximum force pressure setting has been reached.

9.5 TO RECALL FACTORY SET FORCE

1. While holding down the Force Margin Set button (Fig. 16) press the SET button for two (2) seconds.
2. Release both buttons. The default setting should now be recalled.

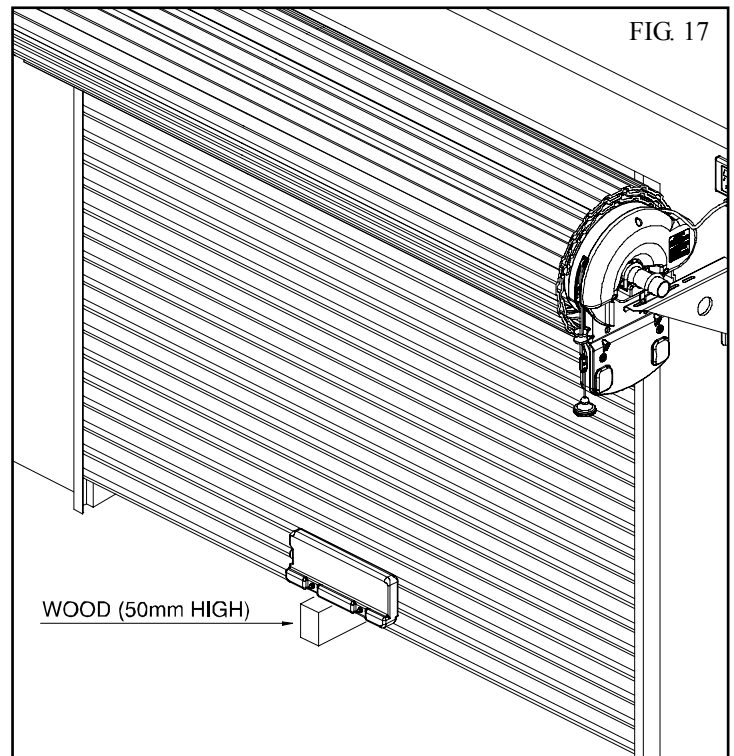
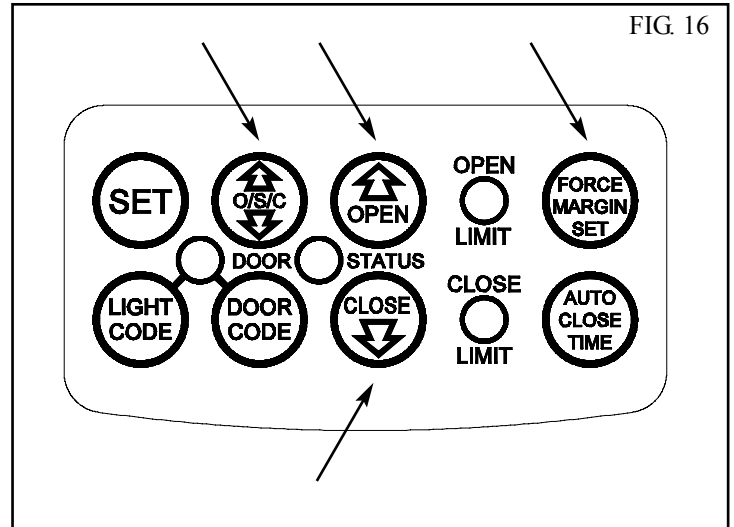

9.6. TO RE-CALCULATE FORCE MARGIN

Press and hold the Set Button for two (2) seconds, the beeper will sound once. The door will start to move and re-calculate force margins. The door can move between the open and close limit positions up to four (4) times (depending on the position of the door and the power up condition). A single beep will be heard once the process is complete. The door is now ready for use.

IMPORTANT NOTE:

After installation ensure that the opener stops or is prevented from opening when the door is loaded with a mass of 20kg fixed centrally at the bottom edge of the door.

CODING TRANSMITTERS

10. SETTING TRANSMITTERS CODES

Make sure to insert the battery into the transmitters. The memory in the openers receiver can store up to 23 remote control transmitters.

10.1 STORING THE TRANSMITTERS CODE

1. Press and hold the Door Code button (**Fig. 18**).
2. Press the button (one of four) on the transmitter you would like to use to control the door for two seconds, pause for two seconds. Press the same button again on the transmitter for two seconds.
3. Release the Door Code button.
4. Press the transmitter button to test if it operates the door.

10.2. SETTING THE TRANSMITTER TO OPERATE THE COURTESY LIGHT

The transmitter can be programmed to operate the courtesy light on the door opener.

1. Press and hold Light Code button (**Fig. 19**).
2. Press the button on the transmitter you would like to use to switch on the light for two seconds, pause for two seconds. Press the same button again on the transmitter for two seconds.
3. Release all buttons to store the transmitter in memory.
4. Press the transmitter button to test if it switches on the light.

10.3. SETTING THE TRANSMITTER TO OPERATE PET (PEDESTRIAN) MODE

1. Press and hold Door Code button and the Close button (**Fig. 19**).
2. Press the button on the transmitter you would like to use to control pedestrian mode for two seconds, pause for two seconds. Press the same button again on the transmitter for two seconds.
3. Release all buttons to store the transmitter in memory.
4. Press the transmitter button to test if it operates the pedestrian mode.

To change the default pedestrian door opening position, refer to Step 17 on page 18.

10.4. SETTING THE TRANSMITTER TO OPERATE VACATION MODE

1. Press and hold Light Code button and the Close button (**Fig. 19**).
2. Press the button on the transmitter you would like to use to control vacation mode for two seconds, pause for two seconds. Press the same button again on the transmitter for two seconds.
3. Release all buttons to store the transmitter in memory.
4. To test, press and hold the transmitter button set for vacation mode for five seconds to set Vacation Mode. Then try a different transmitter that has already been coded into the door - it should be disabled.

FIG. 18

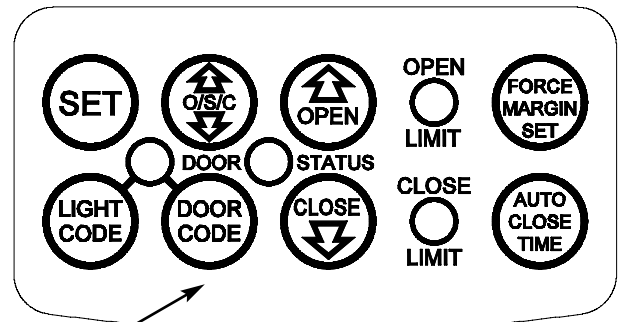

Press and hold Door Code Button

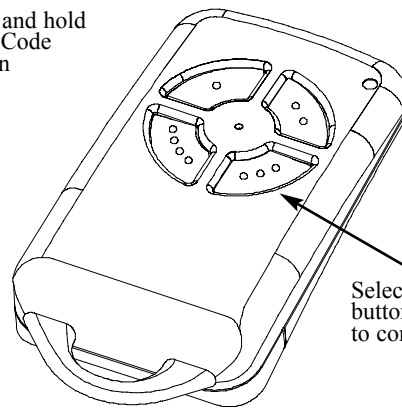

Select one of the four buttons you wish to use to control the door.

FIG. 19

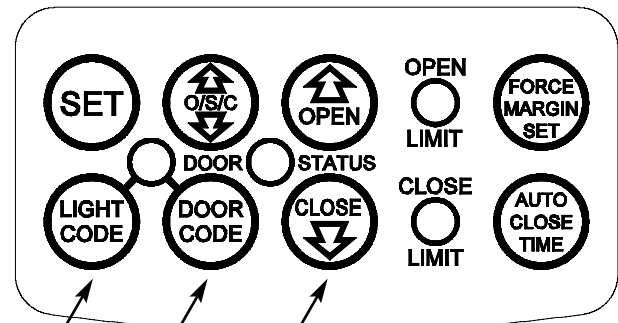

TO RELEASE THE OPENER FROM VACATION MODE

To disable Vacation Mode press the same button for two seconds. Please note that when vacation mode is activated all stored transmitters will be locked out. This mode can only be deactivated by the transmitter which has been stored to activate this mode.

CODING TRANSMITTERS

11. STORING TRANSMITTER(S) FROM A REMOTE LOCATION

Using this method you don't need to have access to the control panel on the Door Opener. However, you do need a transmitter that is pre coded to the controller's receiver.

IMPORTANT NOTE: The Door or Courtesy Light must be activated when the step below is performed. The moving Door or Light switching on is to confirm from a remote location that, the correct button was pressed, and the transmitter is in range of the Opener.

1. Take any pre-coded transmitter. Press the button for the function you require until the door is activated and release.
2. Using a small needle press the button through the Coding Hole for two seconds (Fig. 20)
3. Within 10 seconds take the additional transmitter you wish to code.
4. Press the button (one of four) on the new transmitter you would like to use to control the door for two seconds, pause for two seconds. Press the same button again on the transmitter for two seconds, the button should now be stored.
5. Wait for 10 seconds and then test the new transmitter to see if it operates the door.

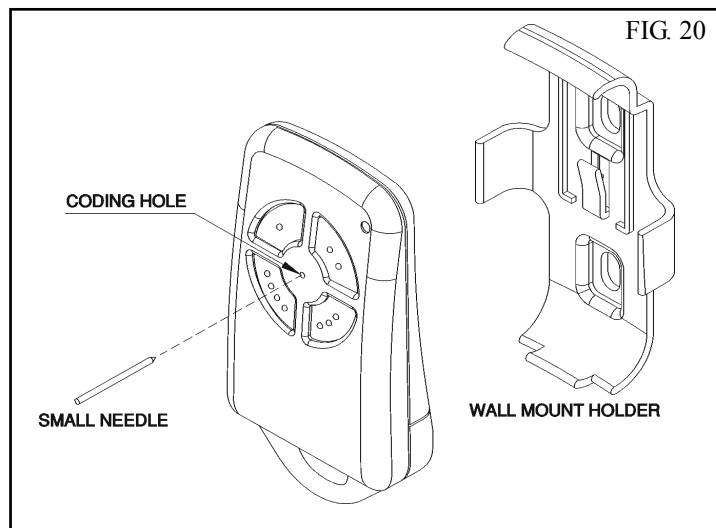

12. DELETING PROGRAMMED CODES

12.1 DELETING A STORED TRANSMITTER CODE

1. Select the transmitter you want to delete.
2. Press and hold the Door Code button (Fig. 21).
3. Press the transmitter button you would like to delete for two seconds. Pause for two seconds. Press the transmitter button again for two seconds.
4. Release the Door Code button. The code should now be deleted. Confirm this by pressing the transmitter button, the door should not respond.

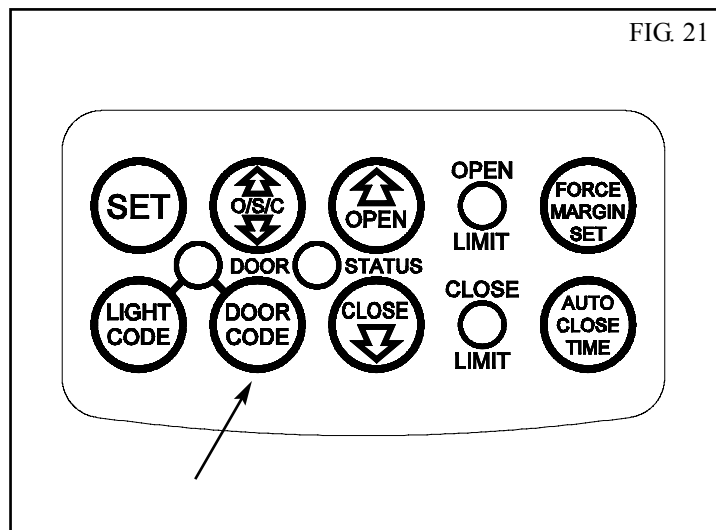

12.2 DELETING ALL STORED TRANSMITTER CODES

1. Turn the Power Off to the Opener.
2. Press and hold the Door Code button (Fig. 21).
3. Turn the Power On again, while holding the Door Code button. The Open Limit, Close Limit and Door Status LED's will illuminate for about five seconds. These LED's will turn Off and the Coding LED will illuminate. Release the Door Code button. All the stored codes including the Courtesy Light codes should now be deleted. Confirm this by trying to operate the door by pressing the transmitters previously used to control the door, the door should not respond.

PE BEAM AND AUTO CLOSE

13. FITTING THE SAFETY PHOTO ELECTRIC BEAM SENSOR (OPTIONAL)

Locate the Photo Electric Beam (P.E.) normally closed contact type in a strategic location within doorway. We recommend 150mm above the floor level and as close as possible to the door opening, inside the garage. Remove shunt from P.E connector (Fig. 22) and connect the wires from the P.E. wiring harness as per Fig. 23.

Note: The wiring diagram is for ATA's Transmitter/Receiver type photo electric beam: model: PE-2 (Order Code 90214) with Wiring Harness (Order Code 01900).

Make sure to align the beams correctly. Follow the manual supplied with the Photo Electric Beam.

WARNING; When using Auto Close Mode and P.E. beams, the doorway must be clear of all obstructions and persons at all times. The location of the beam and manner in which it is installed might not give safety protection at all times. Check to make sure that the height of the beam and type used give maximum protection possible.

14. SETTING OF AUTO CLOSE TIME

IMPORTANT NOTICE: IT IS COMPULSORY TO INSTALL A PHOTO ELECTRIC BEAM BEFORE USING THE AUTO CLOSE MODE.

The Auto Close timer will only start after the Photo Electric Beams (P.E.) path is broken and the auto close time has been set. If the P.E. path is not broken the door will remain open till the path is broken. If the Door Opener incurs an obstruction (not from the P.E.) while closing the door will re-open and not auto close until the path of the P.E. beam is broken again.

SETTING AUTO CLOSE TIME

1. Press in and hold the Auto Close Time button (Fig. 22).
2. While holding in the Auto Close Time button, press the Open button. Each press of this button will add one second to the auto close delay time.
3. To decrease the delay time follow Step 1 and press the Close button. Each press will deduct one second from the auto close time.
4. Press the O/S/C button or transmitter to open the door. When the door is fully opened the Open Limit green LED will flash to indicate that the auto close mode is in operation. Break the path of the P.E. Beam momentarily, this will initialise the auto close mode. The door will pause for the programmed time and start to auto close.

15. MANUAL RELEASE

To switch the opener to manual mode simply pull the red manual release handle down and release. To re-engage the opener repeat the above action (Fig. 24).

Note: The door may move uncontrollably if the spring tension is weak or not set properly or the door is unbalanced. If this occurs do not use the door and contact your installer for service.

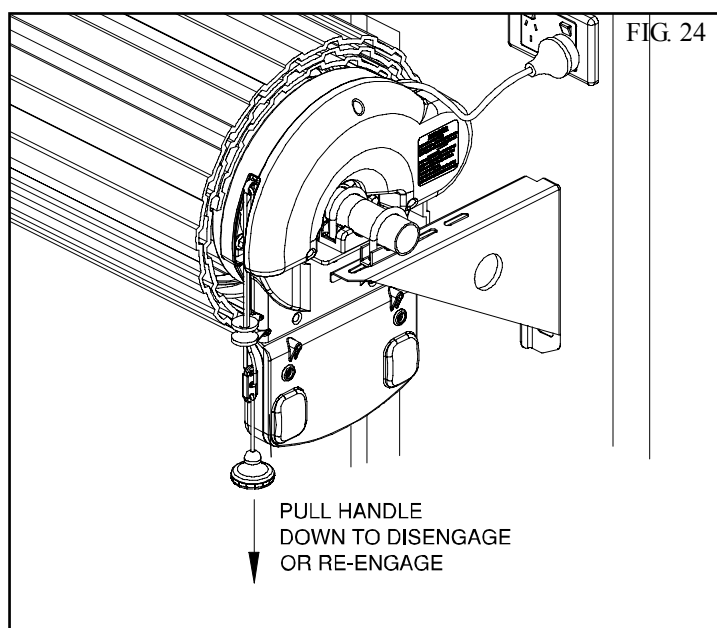
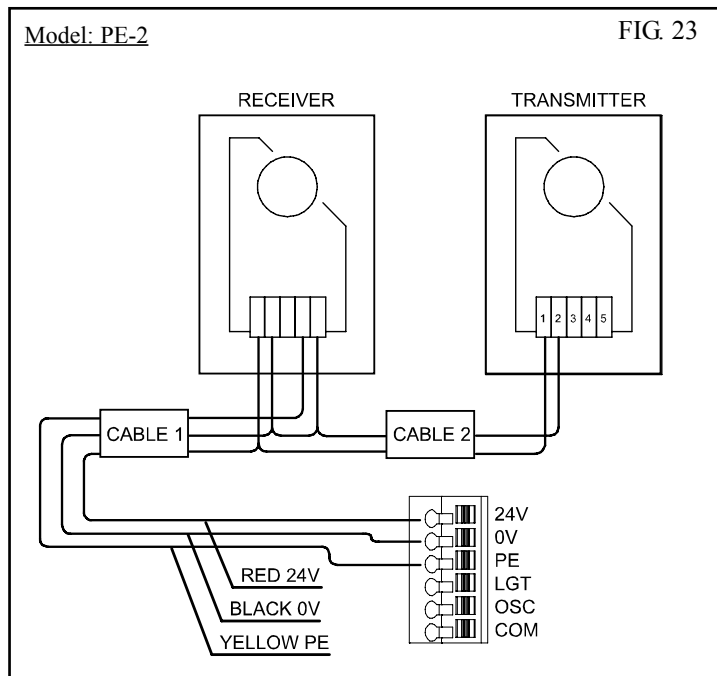
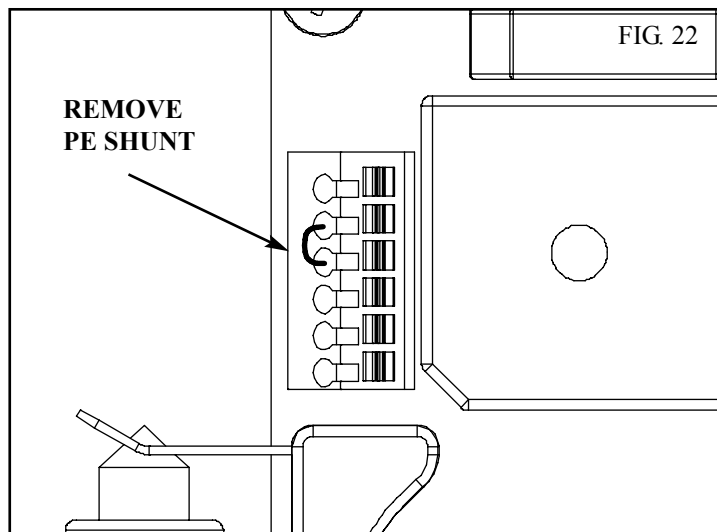

FINAL SET UP

16. SETTING OF COURTESY LIGHT TIME

The preset courtesy light time on the door opener is 3 minutes. This time can be changed by the following:

1. Press in and hold both the Auto Close Time button and Force Margin Set buttons (Fig. 25).
2. While holding in the two buttons, press the Open button. Each press of the button will add 10 seconds to the light time.
3. To decrease the time follow Step 1 and press the Close button. Each press will deduct 10 seconds from the light time.
4. To recall the factory set default light time press in and hold together the Auto Close Time button, the Force Margin Set button and the Set button for about 2 seconds. Release all buttons, the factory set default of 3 minutes will be recalled.

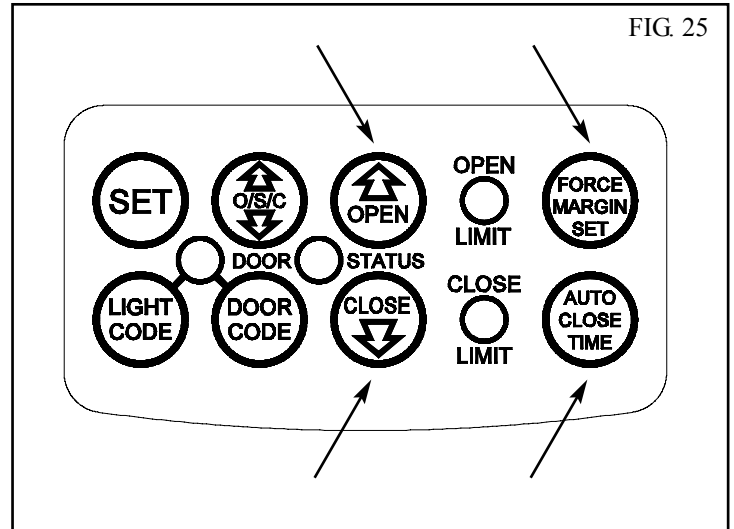

17. SETTING THE PET MODE DOOR OPENING POSITION.

The default PET (Pedestrian) position is about 1/4 turn of the door drum above the closed position. The PET mode status is indicated by both the Open and Close Limit LED's being illuminated. The default position can be changed by the following:

1. Make sure the door is in the closed position. Press and hold the Open button for six (6) seconds (Fig. 26), you should hear three beeps and the Open and Close LEDs will flash rapidly.
2. Press the Open and Close buttons to move the door to your required new pet open position.
3. Press the Set button to record the new position.

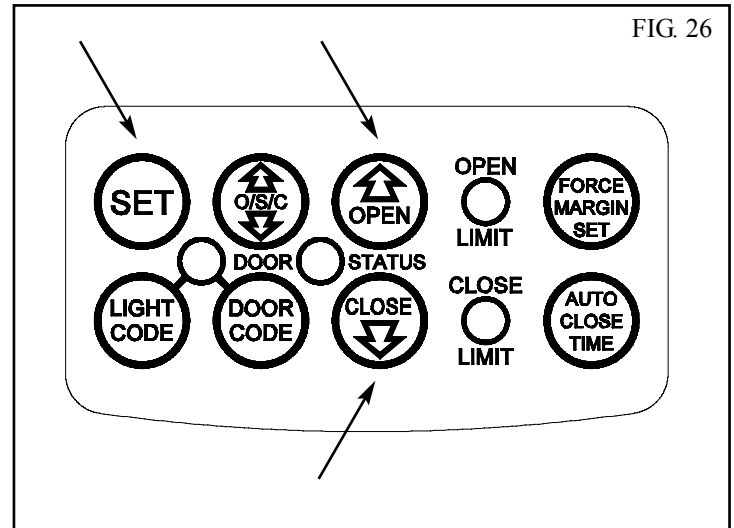

The Pet mode is activated from a transmitter button coded to that function (see Step 10.3 on page 15). When activated the door drives to the preset position from either above or below. If the Pet button is pressed while the door is moving the door will be stopped. If the Pet button is pressed when the door is in the Pet position, then the door will be closed. No auto close is enabled.

18. INSTALLATION OF WALL MOUNTED TRANSMITTER HOLDER

1. Mount the holder in a location out of reach of children (at least 1.5m from the floor) and convenient to the customer. Make sure the door is visible from this location.
2. The transmitter can be easily clipped in and removed from the holder as required.
3. To set the transmitter codes refer to Step 10.

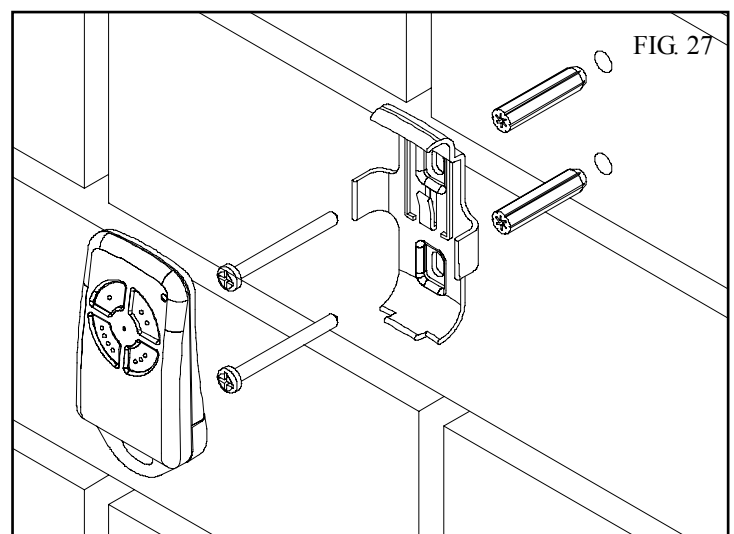

19. RESET ALL FACTORY DEFAULTS

1. Turn power off.
2. Press and hold Set button.
3. Turn power on and continue holding Set until all LEDs are off.

Note: This does not erase transmitter codes stored in memory.

PARAMETERS

DOOR STATUS INDICATORS

| DOOR OPENER STATE | OPEN LED GREEN | CLOSE LED RED | DOOR STATUS LED YELLOW | BEEPER |
|---|---------------------|---------------------|------------------------|----------------------------|
| OPEN | ON | | | |
| CLOSE | | ON | | |
| OPENING | FLASHING | | | |
| CLOSING | | FLASHING | | |
| DOOR TRAVEL STOPPED | FLASHING | FLASHING | | |
| DOOR OBSTRUCTED WHEN OPENING | FLASHING | | | |
| DOOR OBSTRUCTED WHEN CLOSING | | FLASHING | | BEEPS WHILE DOOR IS MOVING |
| OPENER OVERLOADED | ALTERNATING FLASHES | ALTERNATING FLASHES | | |
| DOOR IN OPEN POSITION WITH AUTO CLOSE MODE SELECTED | ONE SECOND FLASHES | | | |
| MAINS POWER INTERRUPTED | RAPID FLASHES | | | |

| BUTTONS | FUNCTION |
|---|---|
| O/S/C | Opens/Stops/Closes the door |
| Door Code | Codes a transmitter button for O/S/C function |
| Light Code | Codes a transmitter button for light function |
| Door Code + Close | Codes a transmitter button for pet (pedestrian) function |
| Light Code + Close | Codes a transmitter button for vacation function |
| Force Margin Set + Open | Increases the obstruction force margin setting |
| Force Margin Set + Close | Decreases the obstruction force margin setting |
| Force Margin Set (then) Set | Reloads the factory set default obstruction force margin setting |
| Auto Close Time (then) Open | Increases the auto close delay time |
| Auto Close Time (then) Close | Decreases the auto close delay time |
| Auto Close Time (then) Set | Disables Auto-Close (set to 0 secs.) |
| Force Margin Set + Auto Close Time (then) Open | Each press of the open button increases the light time by 10 secs. |
| Force Margin Set + Auto Close Time (then) Close | Each press of the open button decreases the light time by 10 secs. |
| Force Margin Set + Auto Close Time (then) Set | Reloads the factory set default light time |
| Close for 6 Secs | Clears the door limits set positions. Limits then need to be reset. |
| Open for 6 Secs. + Door in Closed Position | Enters pet (pedestrian) position mode. |
| Set (then power on) & hold until all LEDs are off | Deletes control parameters excluding transmitter storage memory. |
| Door Code (then power on) & hold until all LEDs are off | Deletes all transmitter stored in memory. |
| Set for 2 sec. | Re-initialises the Opener to re-calculate force margins |

SPECIFICATIONS AND DEFAULT SETTINGS

FACTORY DEFAULT SETTINGS

| | DEFAULT | STEP | MAXIMUM |
|--------------------------|----------|----------|---------|
| MAXIMUM MOTOR RUN TIME | 25 Secs. | — | — |
| COURTESY LIGHT TIME | 3 Mins. | 10 Secs. | 4 Mins. |
| OBSTRUCTION FORCE MARGIN | 8 | 1 | 20 |
| AUTO CLOSE TIME | 0 Secs. | 1 Sec. | 4 Mins. |

TECHNICAL SPECIFICATIONS

| | |
|---|--|
| INPUT VOLTAGE: | 230V- 240V AC 50Hz (Other voltages available upon request e.g. 110V AC 60Hz) |
| CONTROLLER VOLTAGE: | 24V DC |
| MAXIMUM DOOR OPENING:^{1,2} WIDTH: | 5500mm |
| HEIGHT: | 2700mm |
| WEIGHT: | 90Kg |
| RATED LOAD: | 200N |
| OPENER OPENING/CLOSING LIMITS TRAVEL: | 3.0 Turns of Door Drum Wheel |
| OPENER MAXIMUM | |
| OPENING/CLOSING RUN TIME: | 25 Secs. |
| RECEIVER TYPE: | UHF 433.92 MHz. AM Receiver |
| RECEIVER CODE STORAGE CAPACITY: | 23 x 4 Button Transmitter Codes |
| TRANSMITTER FREQUENCY: | 433.92 MHz |
| CODING TYPE: | Code Hopping |
| No. of CODE COMBINATIONS: | Over 4.29 Billion Random Codes |
| CODE GENERATION: | Non-linear Encryption Algorithm |
| PTX-4 TRANSMITTER BATTERY: | A23 Alkaline 12 Volts |
| EAT-1 TRANSMITTER BATTERY: | CR1220 Lithium 3 Volts |
| MOTOR TYPE: | Permanent Magnet Direct Current |
| MOTOR VOLTAGE: | 24V DC |
| GLOBES: | Festoon Type - 15w 24V DC |

Note:

1. The maximum continuous curtain domestic roll up door opening that the EasyRoller can be installed on is 5500mm wide by 2700mm high. The door must be well balanced. A person should be able to lift the door up manually with very little effort in case of an emergency.
2. Intermittent operations may occur in areas which experience very strong winds. The strong wind puts extra pressure on the door and tracks which may in turn trigger the safety obstruction detection system intermittently.

TROUBLE SHOOTING

| SYMPTOM | POSSIBLE CAUSE | REMEDY |
|--|---|--|
| Door will not operate. | Mains power not switched on. Door is obstructed. Door is locked or motor jammed. Door tracks/hardware damaged. | Switch on mains power. Remove obstruction. Unlock door or remove jam. Door requires service/repair by qualified technician. |
| Door starts to close but automatically reverses to open position. | Adverse weather conditions (wind or cold) causing door to stiffen and become tight in the tracks. Possible obstruction in the doorway. | Increase force margin setting See Step 9.3 on page 14. Or re-calculate force margin. See Step 9.6 on page 14. Remove obstruction. |
| Door operates from drive unit (O/S/C) button but not from transmitter.* See note. | Transmitter code not stored in memory. Flat Battery. | Code transmitter in to openers memory. Refer Step 10.1 on page 15. Replace battery - A23 Alkaline 12V. |
| Door will not close fully. | Door limits positions need to be reset. | Reset limits positions. See Page 12. |
| Door will not open fully. | Door limits positions need to be reset. | Reset limits positions. See Page 12. |
| Courtesy light not working. | Globe blown. | Replace globe - festoon type 15W 24V DC. |
| Globe keeps blowing. | Incorrect globe voltage - must be 24V DC. | Replace globe - festoon type 15W 24V DC. |
| Auto close not working. | PE Beam or wiring faulty PE Beam not aligned correctly. PE Beam is obstructed. Door obstructed when closing. Auto close time not set. Auto close mode not set. | Repair PE Beam or replace wiring. Re-align optics. See PE Instructions. Remove obstruction from the path of PE. Remove obstruction. See Step 14 on page 17. See Step 14 on page 17. |

***Please Note:** Some areas may be prone to excessive radio interference brought on by devices such as cordless telephones, wireless stereo headphones and baby monitors. It is possible that these devices could cause a degree of interference such as to greatly reduce the range of the transmitter. In such an instance please contact your ATA dealer for an alternative frequency replacement kit. As this is not a warrantable situation but an environmental issue charges may apply for the changeover.

| DATE | MAINTENANCE PERFORMED BY | SIGNATURE | AMOUNT | INV. No. |
|------|--------------------------|-----------|--------|----------|
| | | | | |
| | | | | |
| | | | | |
| | | | | |
| | | | | |
| | | | | |
| | | | | |
| | | | | |
| | | | | |
| | | | | |

Please Note: Failure to maintain your garage door may void the warranty for your garage door opener.

SPARE PARTS LIST

| ITEM NO. | DESCRIPTION | ORDER CODE |
|----------|--------------------------------------|------------|
| 1 | DRIVE CHASSIS | 03011 |
| 2 | CLUTCH GEARBOX MOTOR ASSY 12 | 00372 |
| 3 | HEX SERRATION HEAD SCREW M6x16 | 10170 |
| 4 | TRANSFORMER TDB-100-03 KIT | 02020 |
| 5 | CORD GRIP GROMMET SBR5-2 | 05605 |
| 6 | POWER CORD 1.5M W/2P+1R GDO-2/4 | 14150 |
| 7 | TERMINAL BLOCK 500/02DS 2 POS | 05421 |
| 8 | CAP POLYFILM 0.1UF K X2.275VAC | 07575 |
| 9 | PAN HEAD SCREW W/T L WASHER M3x14 | 10361 |
| 10 | PAN HEAD SCREW W/WASHER M4x10 | 10340 |
| 11 | CLAMPING SADDLE BRACKET | 03171 |
| 12 | HEX SERRATION HEAD SCREW M8x16 | 10122 |
| 13 | SUPPORT CHASSIS | 16205 |
| 14 | GROMMET 101422 | 05603 |
| 15 | TIMING ASSY | 01732 |
| 16 | STRING GUIDE | 16420 |
| 17 | CONTROL BOARD CB-15 V-1.02 | 00971 |
| 18 | TIMING HARNESS ASSY | 01791 |
| 19 | TAPTITE SCREW 'P' M4x10 | 10570 |
| 20 | TAPTITE SCREW 'P' M4x6 | 10582 |
| 21 | INTERNAL GEAR | 16020 |
| 22 | CLAMP WASHER | 11180 |
| 23 | RETAINING RING STW 45 | 10650 |
| 24 | MAIN COVER ASSY | 16256 |
| 25 | TIMING COVER | 03225 |
| 26 | GLOBE 24V/15W 15x44 | 05440 |
| 27 | LIGHT DIFFUSER ASSY | 05110 |
| 28 | INDUSTRIAL SADDLE | 03175 |
| 29 | U-BOLT M8 | 10141 |
| 30 | HEX SERRATION FLANGE NUT M8 | 10148 |
| 31 | TAPTITE SCREW 'P' M4x8 | 10580 |
| 32 | PAN HEAD SCREW W/WASHER M4x8 | 10320 |
| 33 | FLAT WASHER I.D. 8 | 11020 |
| 34 | EASY ACCESS TRANSMITTER PACK GDO-4 | 01237 |
| 35 | LITHIUM BATTERY 3V | 13020 |
| 36 | TRANSMITTER GBR PTX-4 (GREY BUTTONS) | 01210 |
| 37 | TRANSMITTER RBR PTX-4 (RED BUTTONS) | 01211 |
| 38 | PTX HOLDER | 05196 |
| 39 | ALKALINE BATTERY A23 12V | 13030 |
| 40 | PLASTIC WALL PLUG PACK | 01479 |
| 41 | COVER WITH D/S TAPE | 71040 |
| 42 | WEIGHT BAR | 71190 |
| 43 | WEIGHT BAR ACCESSORY | 01782 |

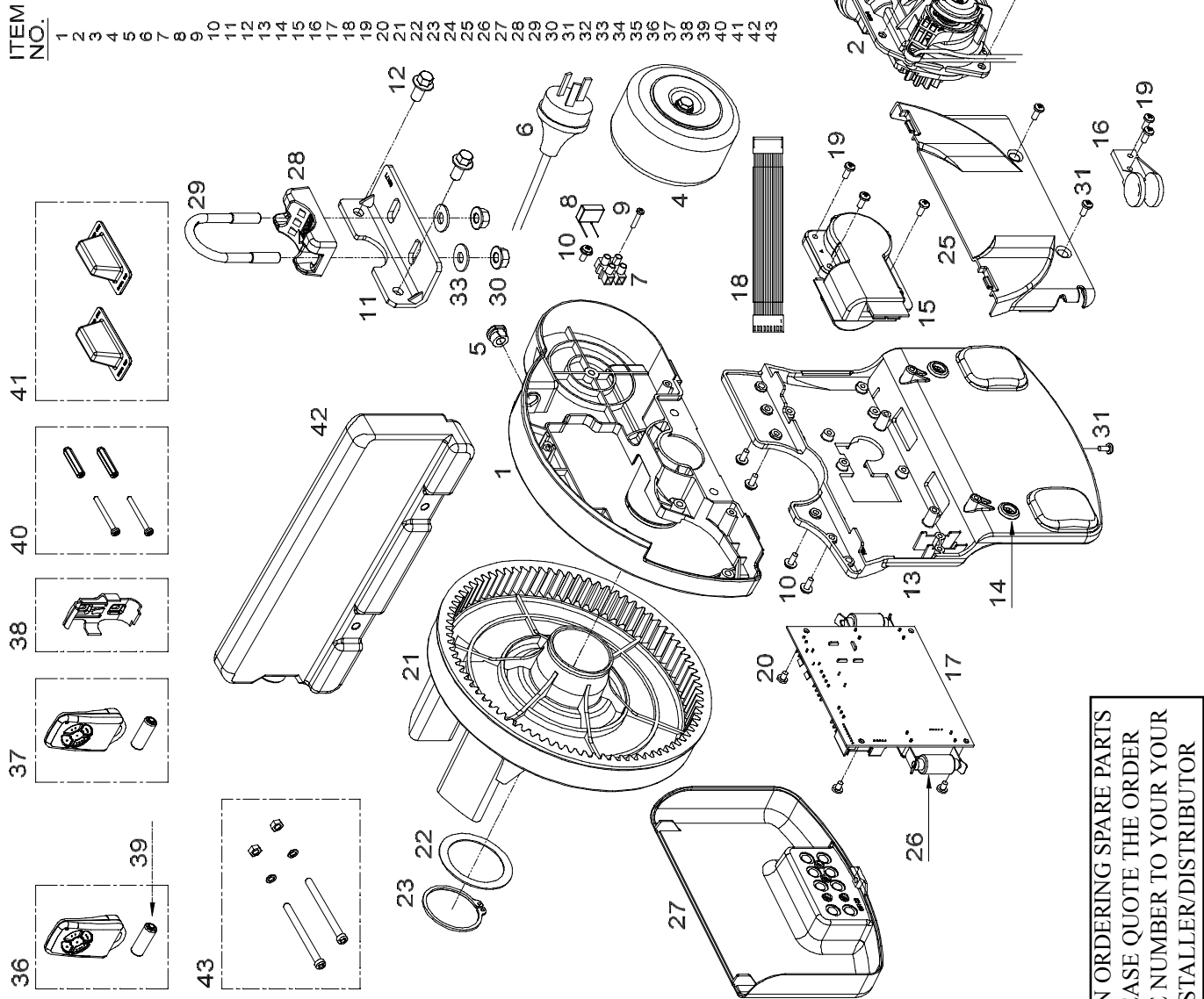

WHEN ORDERING SPARE PARTS
PLEASE QUOTE THE ORDER
CODE NUMBER TO YOUR YOUR
INSTALLER/DISTRIBUTOR

WARRANTY AND EXCLUSION OF LIABILITY

Subject to all of the matter set out below, Automatic Technology Australia Pty Ltd ("ATA") warrants the EasyRoller® Roll Up Door Opener ("The Product") for twenty four (24) months, from the date of purchase (specified in the sales docket receipt) that the product is free of any defects in material and workmanship rendering it unmerchantable.

This warranty referred to above applied only where:

- a) the consumer seeking to rely on the said warranty;
 - 1) returns the product which it claims to be defective; and
 - 2) presents the relevant sales docket and this warranty document to the retailer from whom the product was purchased to confirm that date of purchase; and
- b) the purchaser notified ATA or the retailer from whom the product was purchased of the alleged defect in the product immediately upon experience or learning of the alleged defect.

Except for the warranty against defects in material and workmanship set out above, ATA gives no warranties of any kind whatsoever, whether express or implied or whether statutory or at common law, in relation to the product, and all warranties of fitness for particular purpose and other warranties of whatsoever kind relating to the product are hereby declined. Without limiting the generality of the foregoing, ATA disclaims any liability of whatsoever nature in respect of any claim or demand loss or damage which arises out of;

- a) accidental damage to or normal wear and tear to the product or to the product's components;
- b) flood, rain, water, fire or lightning;
- c) incorrect, improper or unreasonable maintenance and/or use;
- d) installation, adjustment or use other than ATA which is not in accordance with the instructions set out in installation instructions incorporated in the document;
- e) attempted or complete modification or repairs to the Product carried out by a person who is not authorised by ATA to carry out such modification or repairs;
- f) faulty or unsuitable wiring of structure to which the Product is fixed or connected;
- g) radio (including citizen band transmission) or any electronic interference;
- h) blown fuses or damage caused by electrical surges;
- i) damage caused by insects.
- j) installation of the product in a commercial or industrial situation

ATA's liability under the warranty set out above is limited, at ATA's absolute option, to replacing or repairing the product which ATA, in its unfettered opinion, considers to be defective either in material and/or workmanship or to credit the dealer with the price at which the product was purchased by the dealer. This warranty does not extend to cover labour for installation.

Where the Product is retailed by any person other than ATA, except for the warranty set out above, such person has no authority from ATA to give any warranty or guarantee on ATA's behalf in addition to the warranty set out above.

Purchased From _____ Phone _____
Installed By _____ Date _____
Serial No. _____

AUTOMATIC TECHNOLOGY AUSTRALIA PTY LTD

ABN 11 007 125 368

17-19 Advantage Rd, Highett, Victoria, Australia 3190

Tel: +61 3 9532 2788 Fax: +61 3 9532 2799

Web: www.ata-aust.com.au Email: sales@ata-aust.com.au